

# SEP50610 (126POLE)

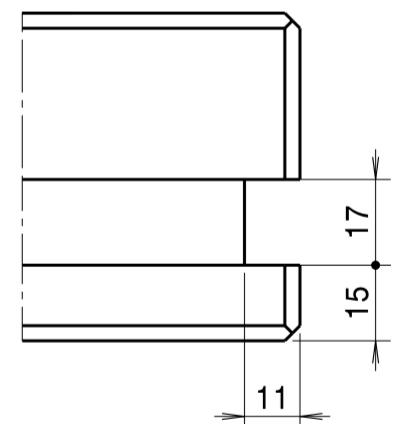
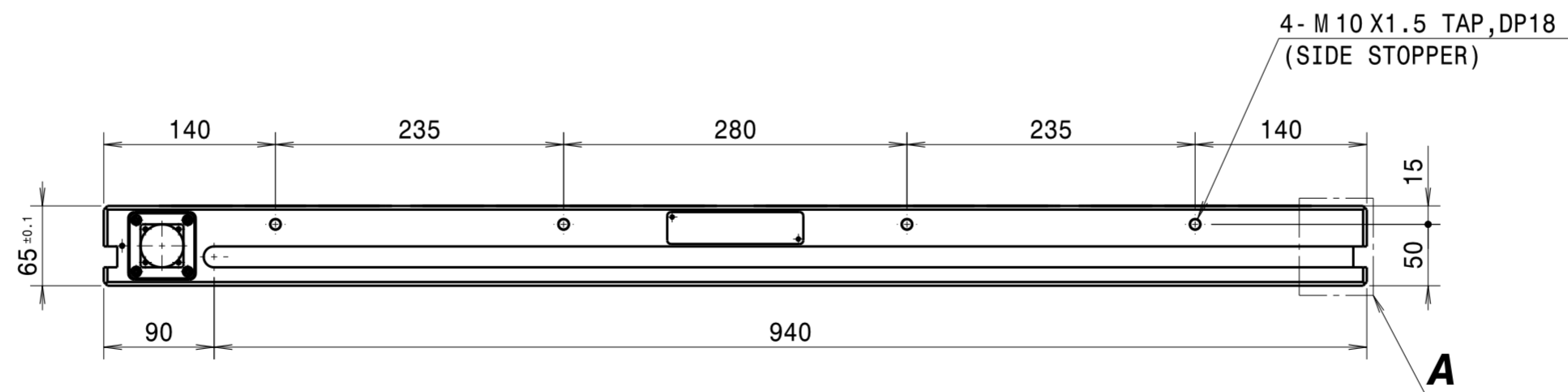
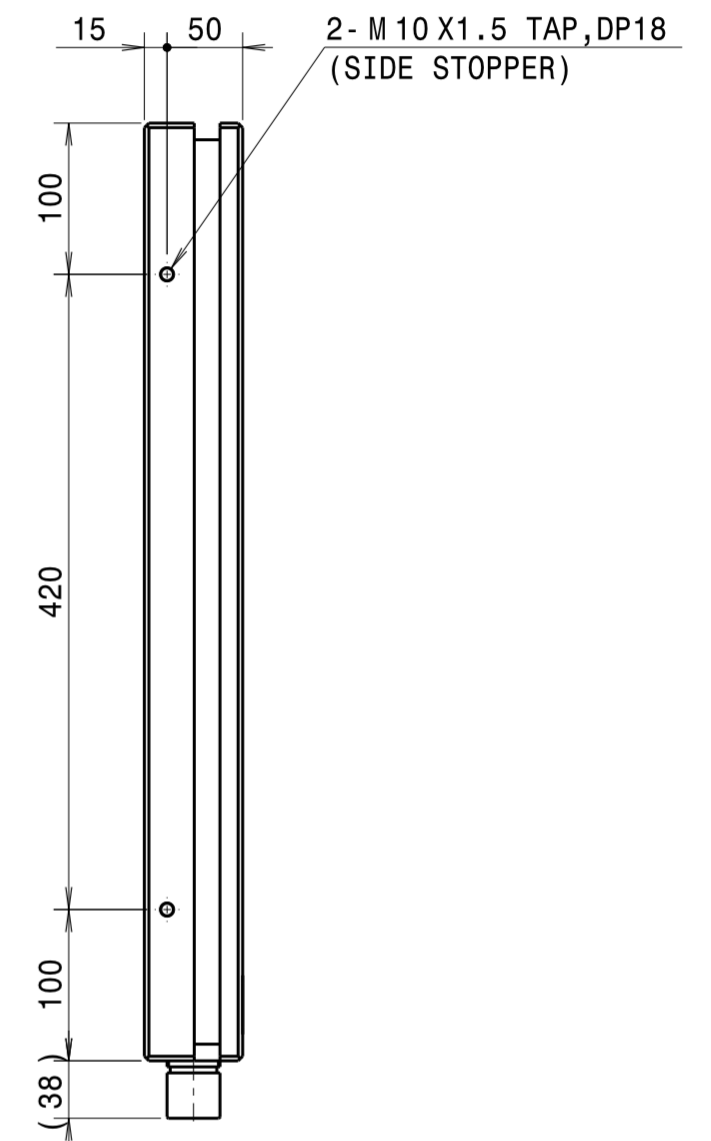
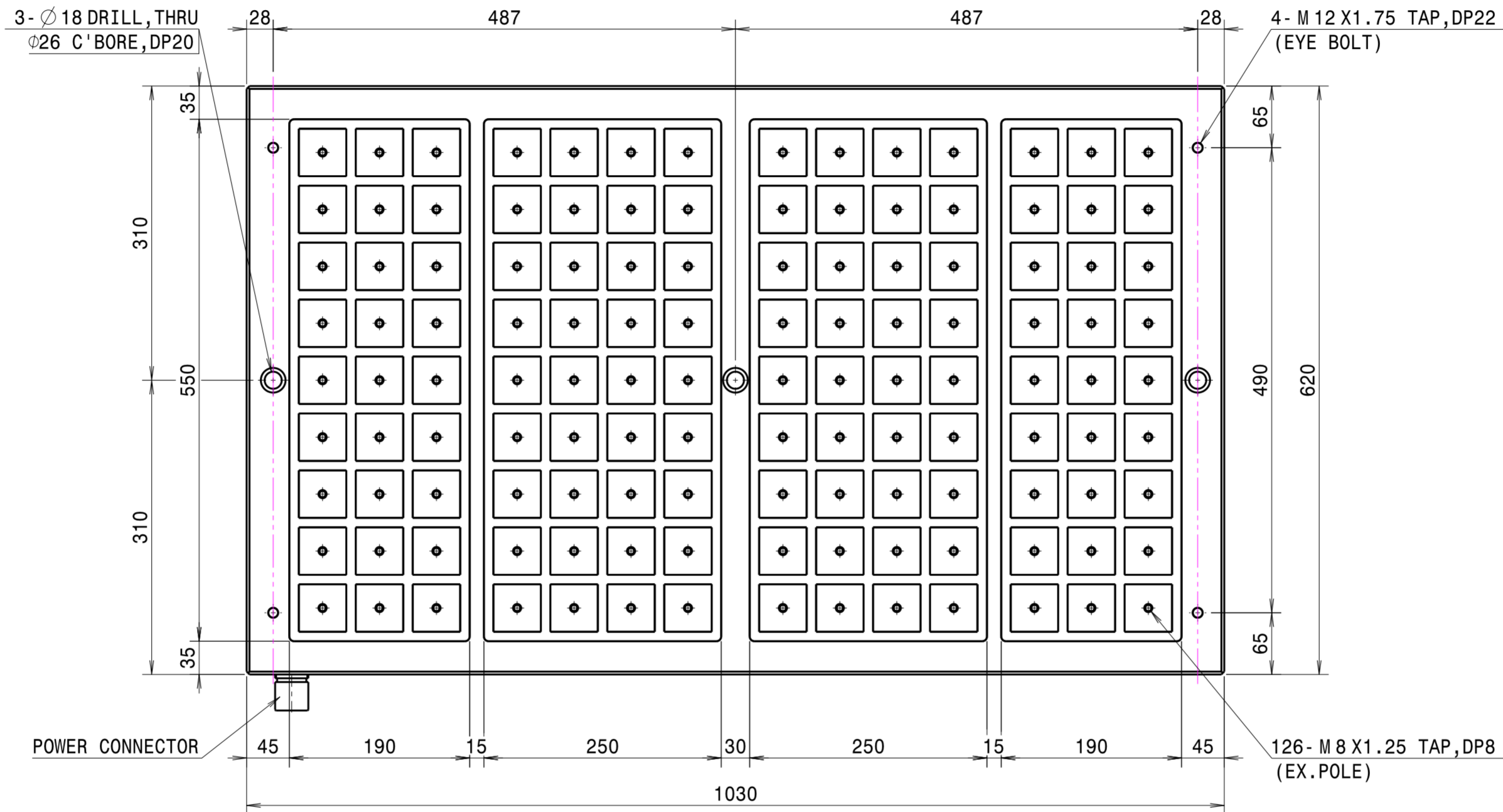
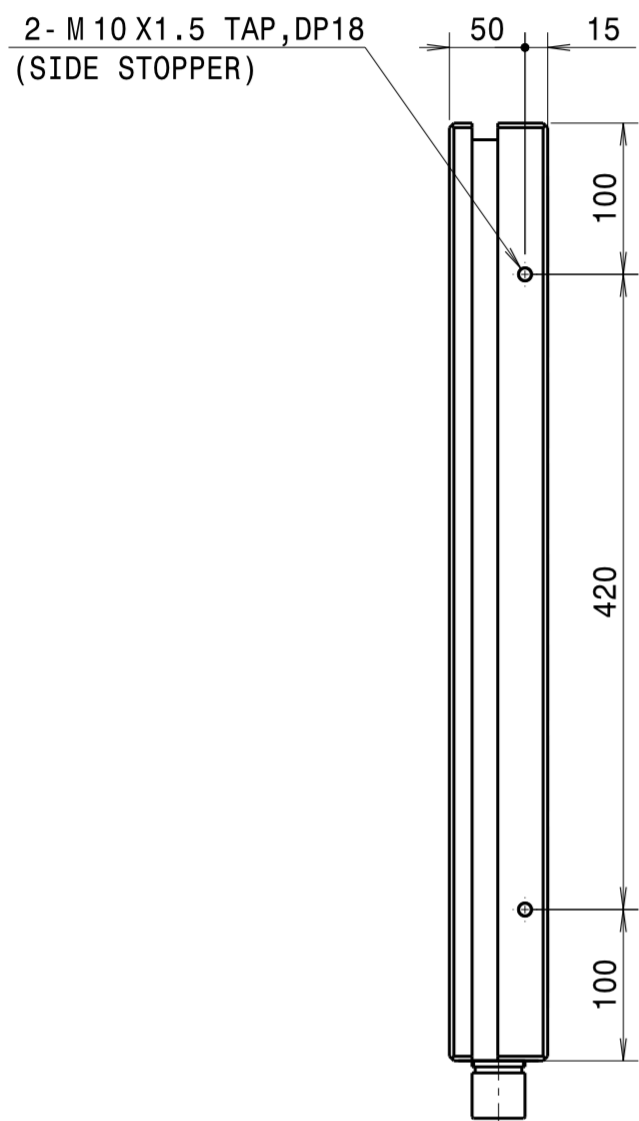
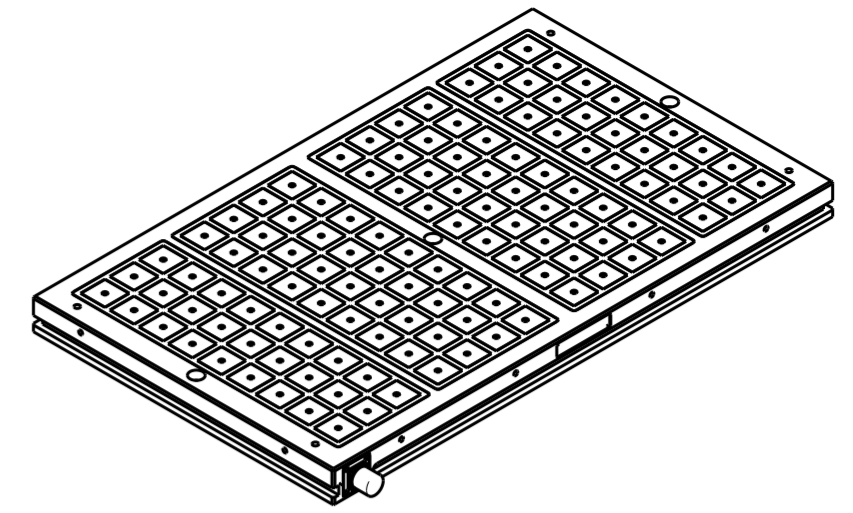
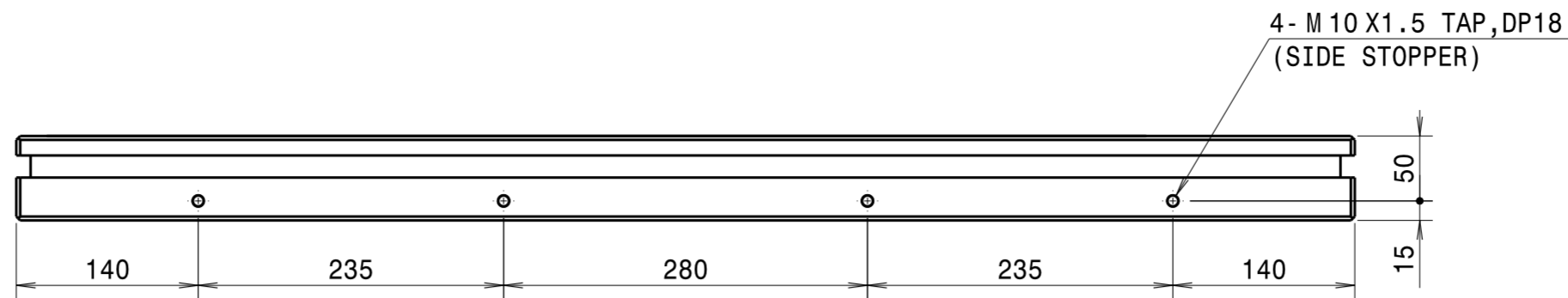

**Detail A (2:3)**  
**(SIDE SLOT)**

						SURFACE FINISH	~ (▽), (▽▽), (▽▽▽)	APPROVED	TITLE		SEP5061000-HL_ASS'Y	Q'TY	1	
						GENERAL TOLERNCE (MACHINING)		CHECKED	ASS'Y		N/A		W.T (kg)	N/A
						OVER	TO			MODEL	N/A		SCALE	1/5
						- 6	±0.1			N/A	MAT.		N/A	
						6 - 30	±0.2			DRG. NO.	A2		SEP5061000-HL	
						30 - 120	±0.3		DESIGNED	HS.CHO		1/1		①
						120 - 315	±0.5			REF. DRG. NO.	N/A		②	
						315 - 1000	±0.8							
						1000 - 2000	±1.2							
						2000 - 4000	±2.0		DRAWN	When				
SUFFIX	MARK	SUBJECT		DATE	NAME	CHECKED			<b>상원엔지니어링</b>					