

SEP50608S (99POLE)

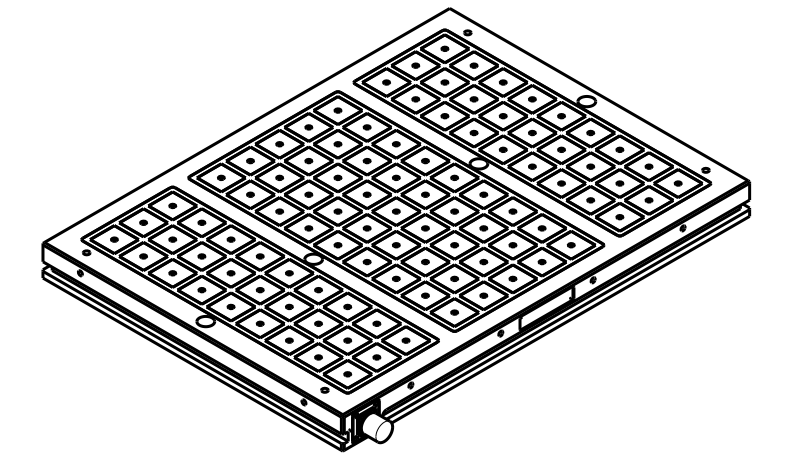

Isometric view (1:11)

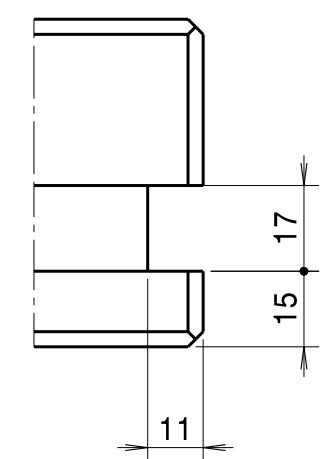
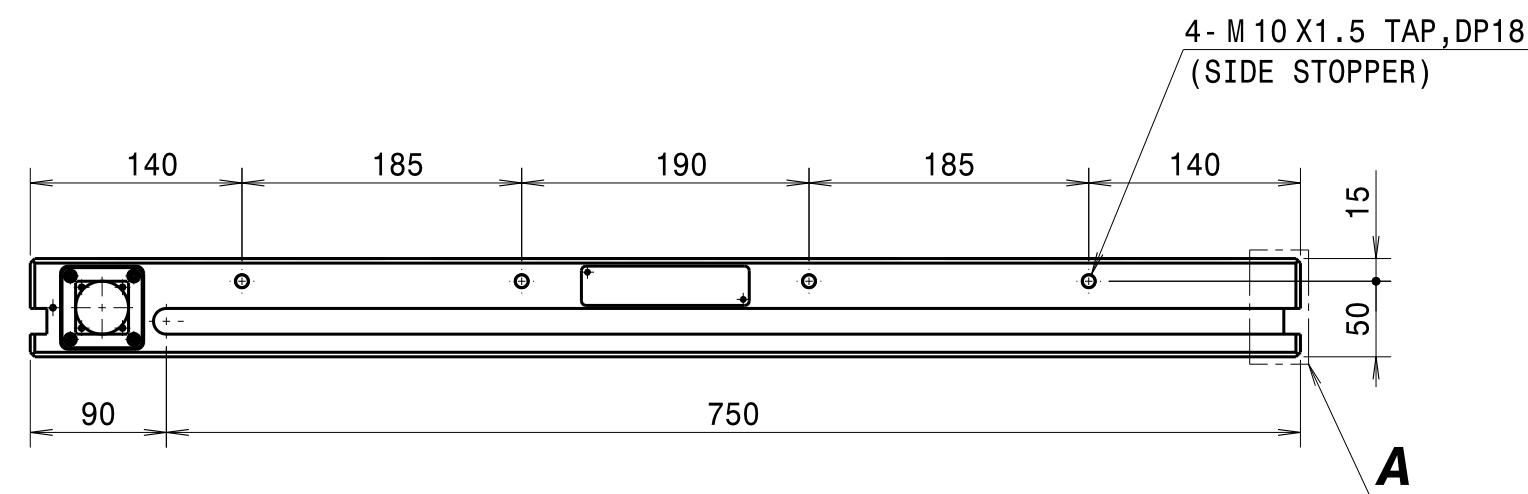
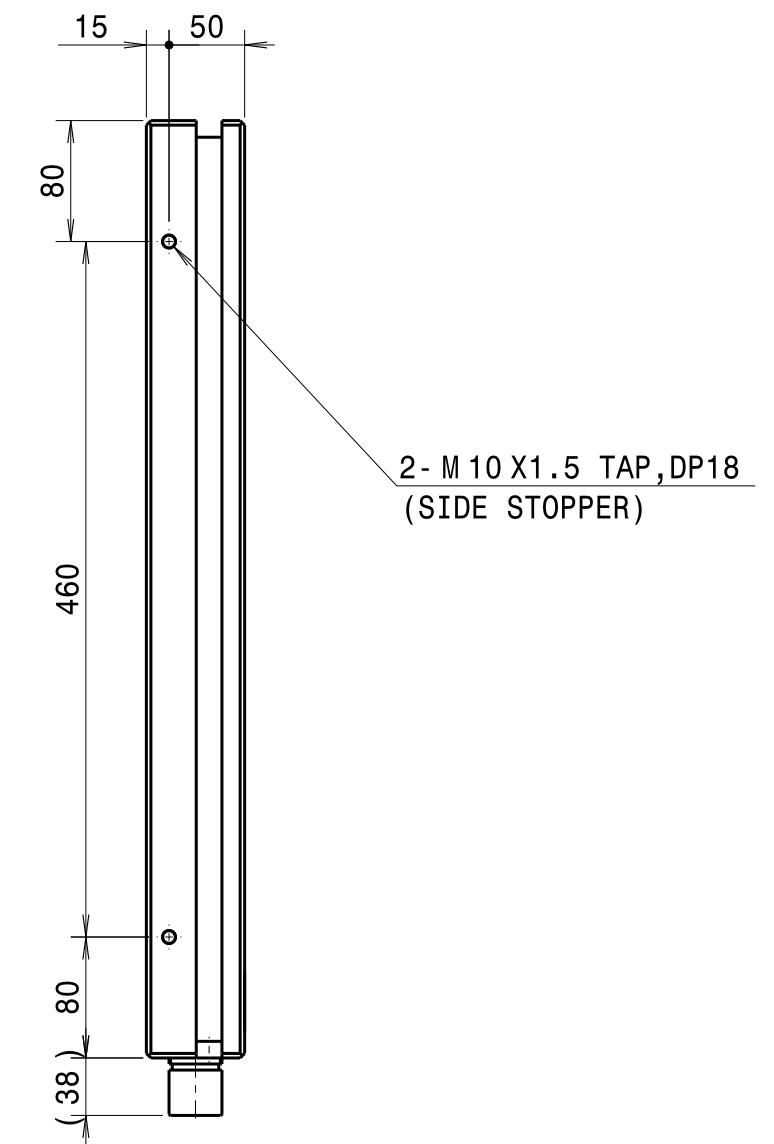
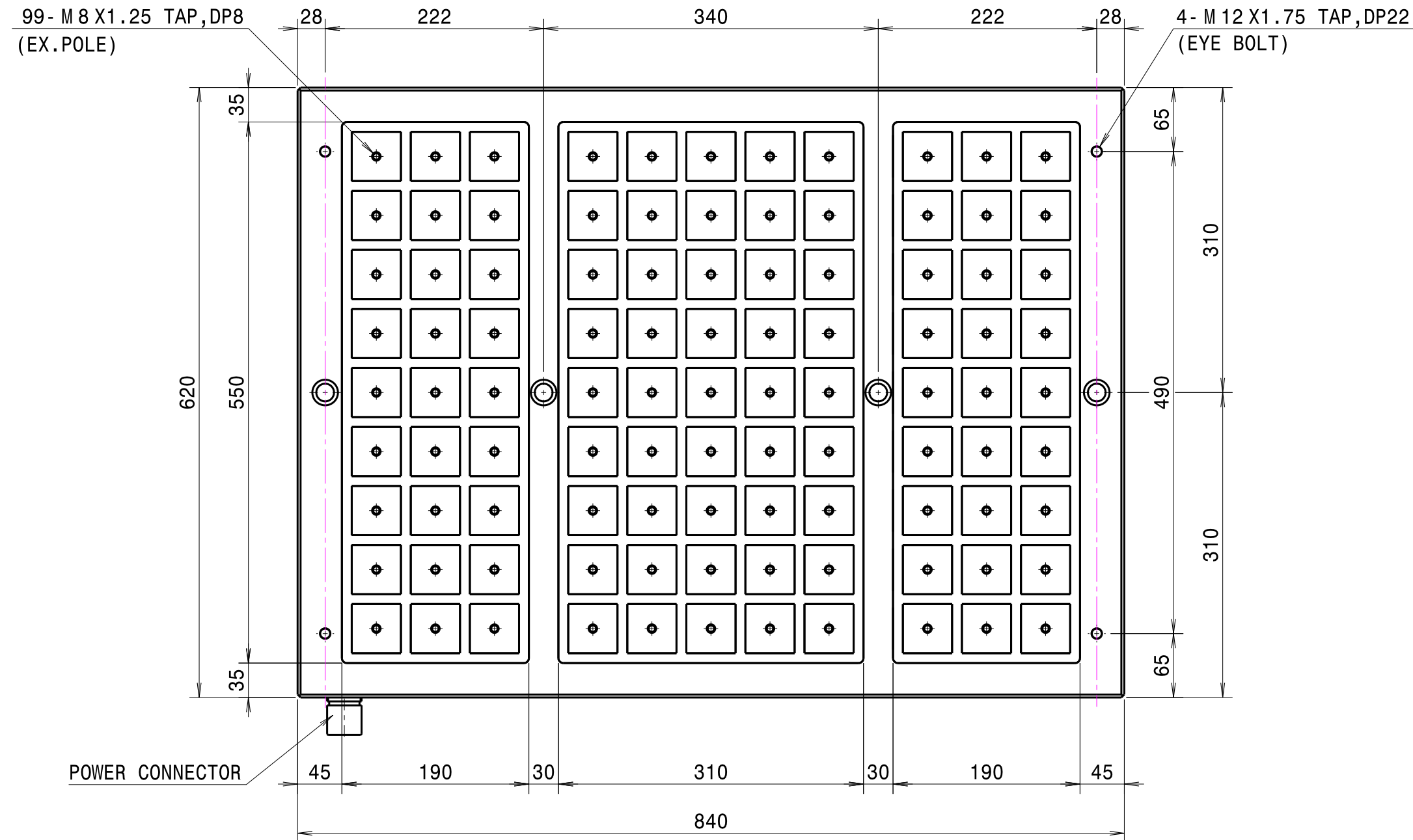
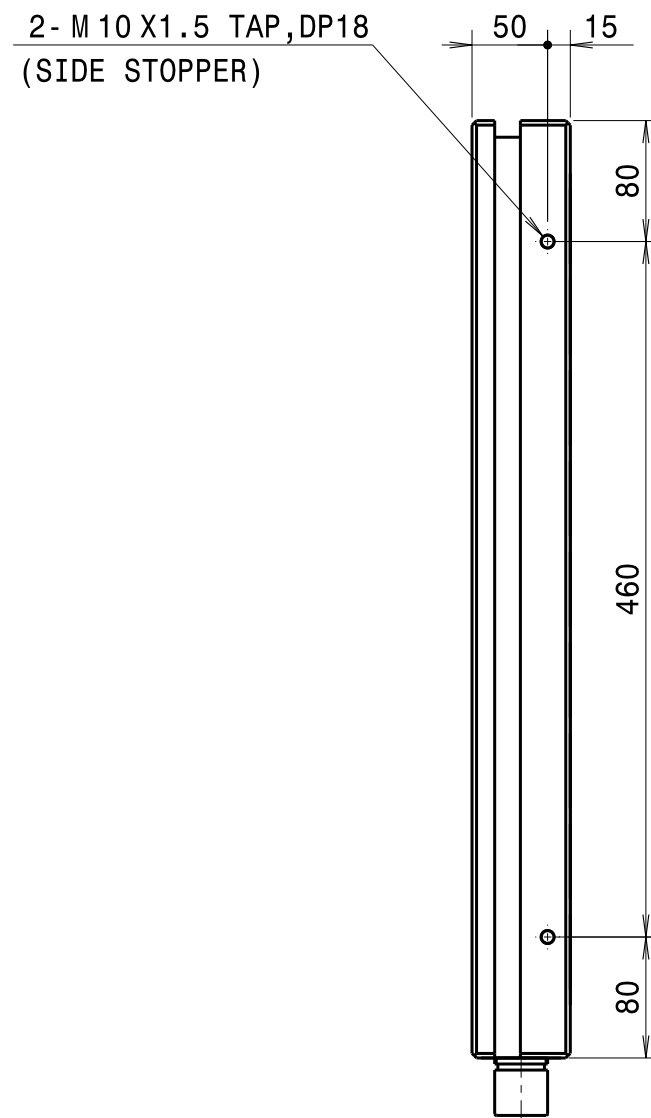

Detail A (2:3)
(SIDE SLOT)

						SURFACE FINISH	~ (▽), (▽▽), (▽▽▽)	APPROVED		TITLE	SEP50608S00-HL_ASS'Y	Q'TY	1	
						GENERAL TOLERANCE (MACHINING)		CHECKED		ASS'Y	N/A	W.T (kg)	N/A	
						OVER	TO	GENERAL CHAMFER	C1.0	MODEL	N/A	SCALE	1/5	
						- 6	±0.1	HEAT TREATMENT	H _R C N/A	MAT.	N/A			
						6 - 30	±0.2	HEAT TREATMENT HARDNESS		DRG. NO.	A2	REF. DRG. NO.	SEP50608S00-HL	1/1
						30 - 120	±0.3	HEAT TREATMENT METHOD	N/A	DESIGNED	SJ.KIM			
						120 - 315	±0.5			DRAWN	When			
						315 - 1000	±0.8							
						1000 - 2000	±1.2	SURFACE TREATMENT	N/A					
						2000 - 4000	±2.0							
SUFFIX	MARK	SUBJECT		DATE	NAME	CHECKED								

