

SEP50508S (77POLE)

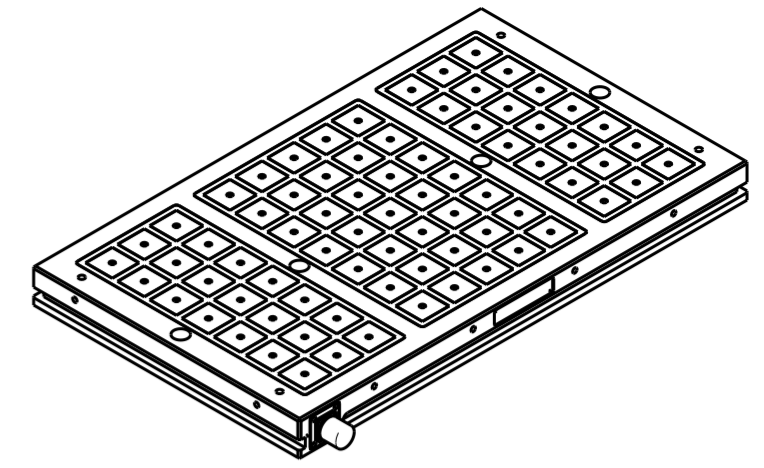

Isometric view (1:10)

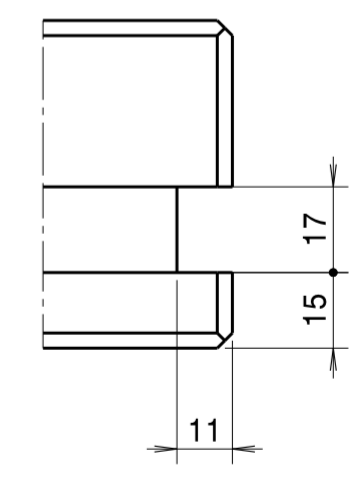
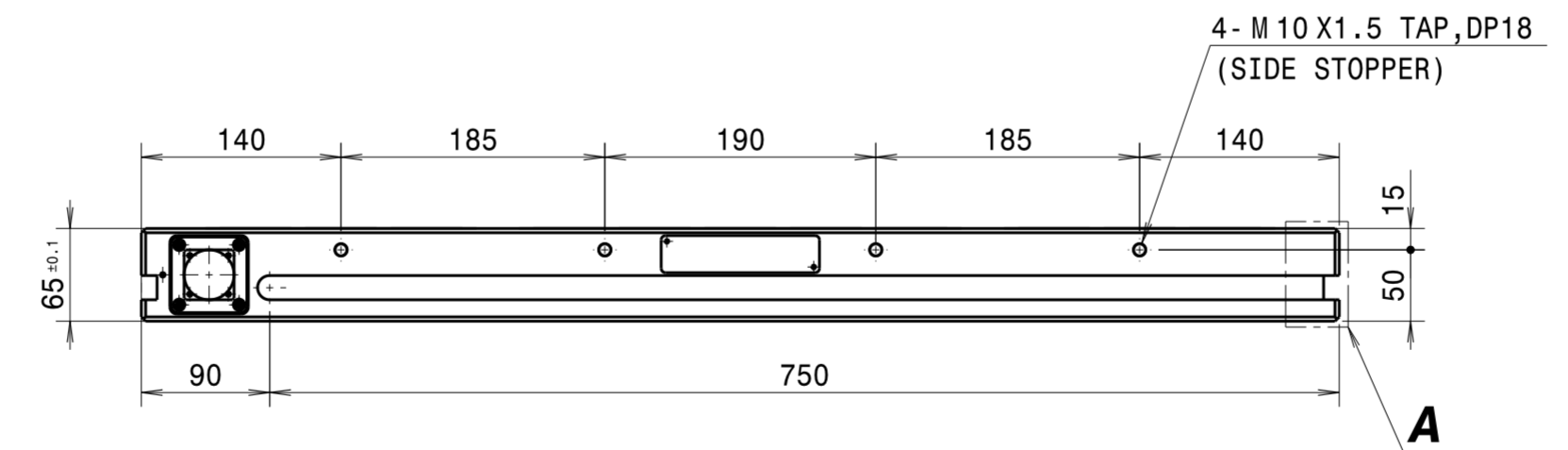
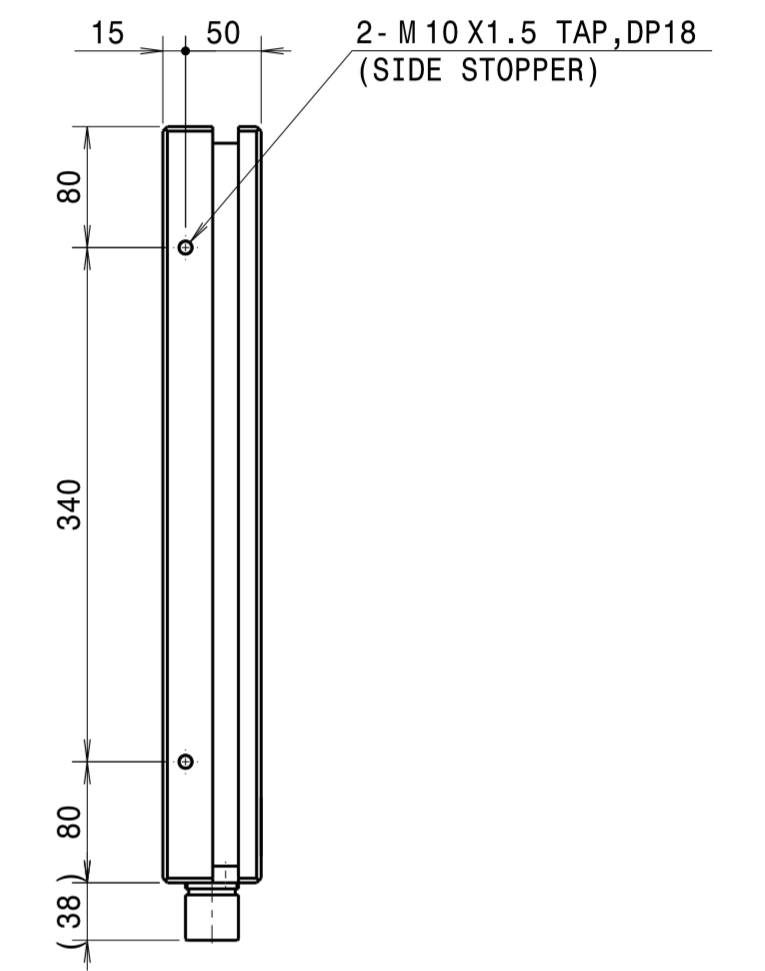
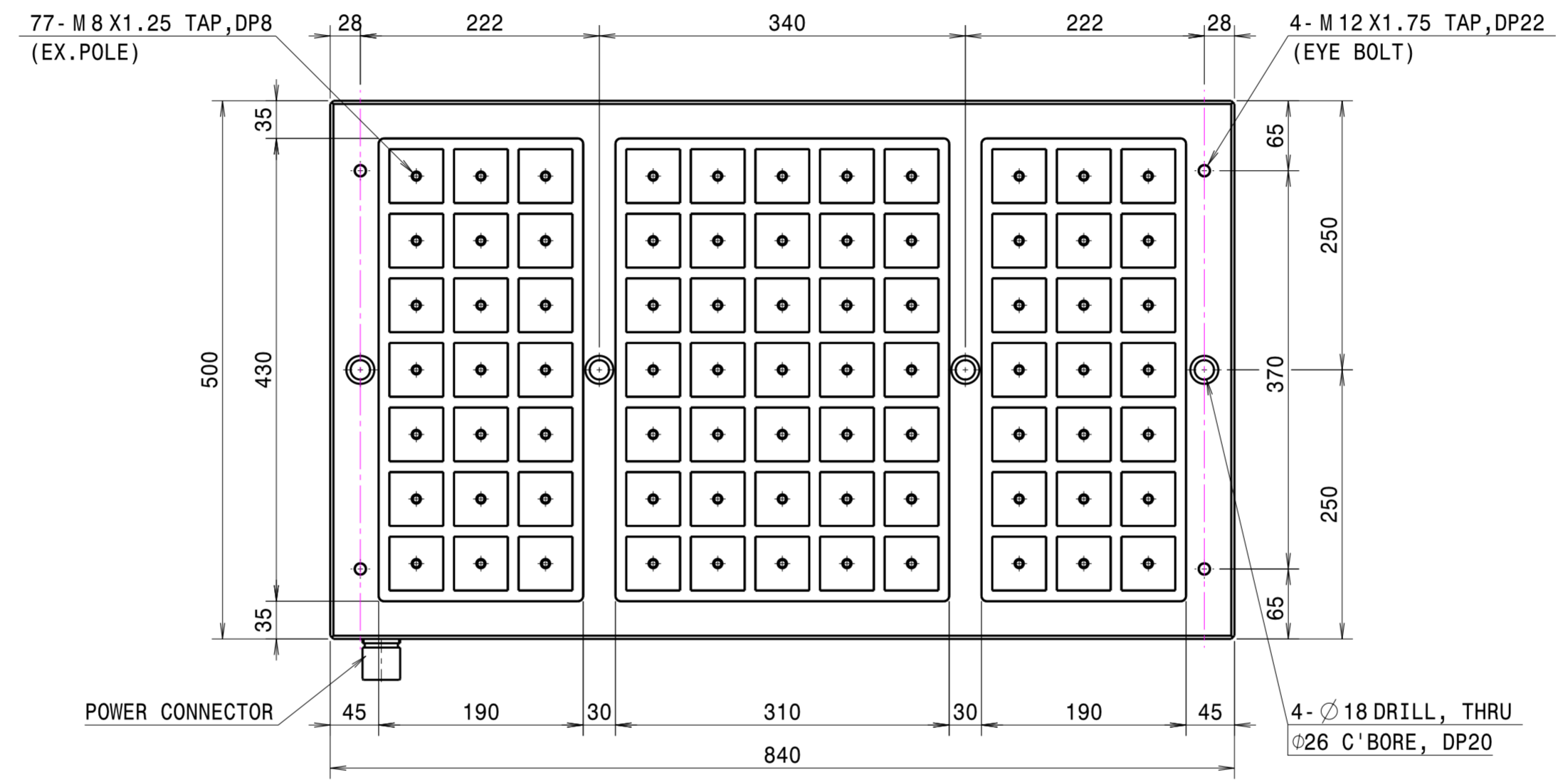
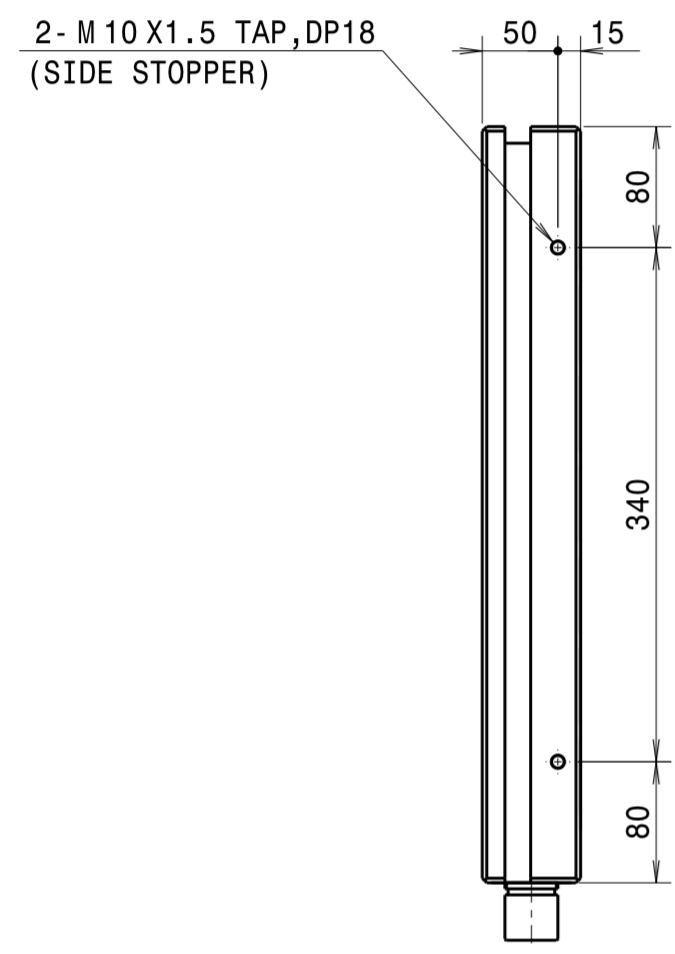
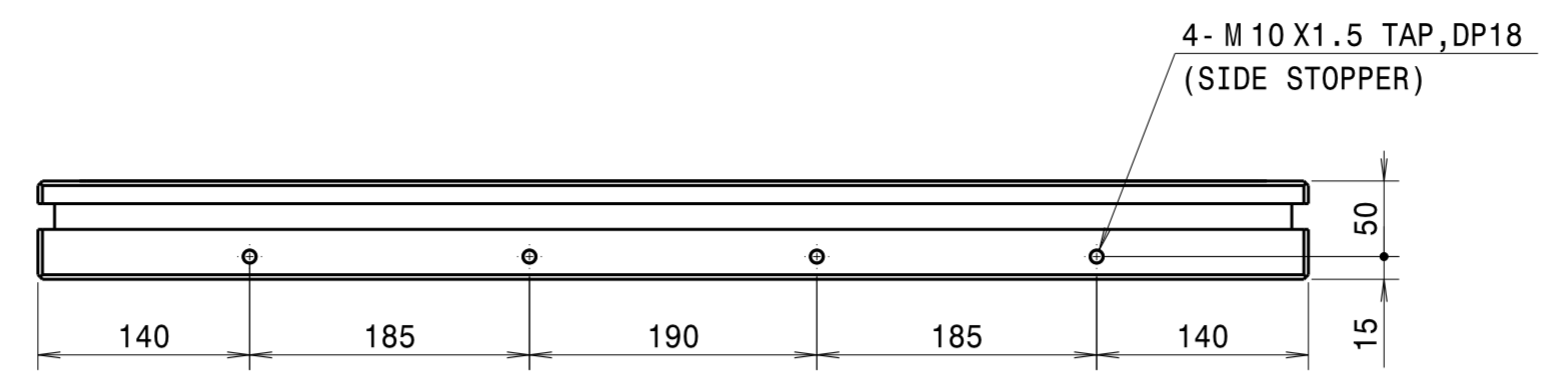

Detail A (2:3)
(SIDE SLOT)

						SURFACE FINISH	~ (▽), (▽▽), (▽▽▽)	APPROVED		TITLE	SEP50508S00-HL_ASS'Y	Q'TY	1
						GENERAL TOLERANCE (MACHINING)		CHECKED		ASS'Y	N/A	W.T (kg)	N/A
						OVER	TO	±0.1		MODEL		SCALE	1/5
						6	30	±0.2		N/A			
						30	120	±0.3		DRG. NO.	A2		
						120	315	±0.5	DESIGNED	SJ.KIM	REF. DRG. NO.	SEP50508S00-HL	1/1
						315	1000	±0.8					
						1000	2000	±1.2					
						2000	4000	±2.0	DRAWN	When			
SUFFIX	MARK	SUBJECT		DATE	NAME	CHECKED							

