

SEP50508 (70POLE)

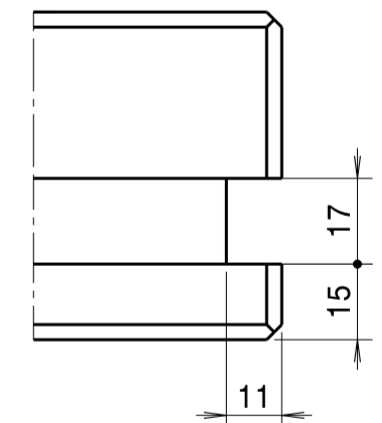

Detail A (2:3)
(SIDE SLOT)

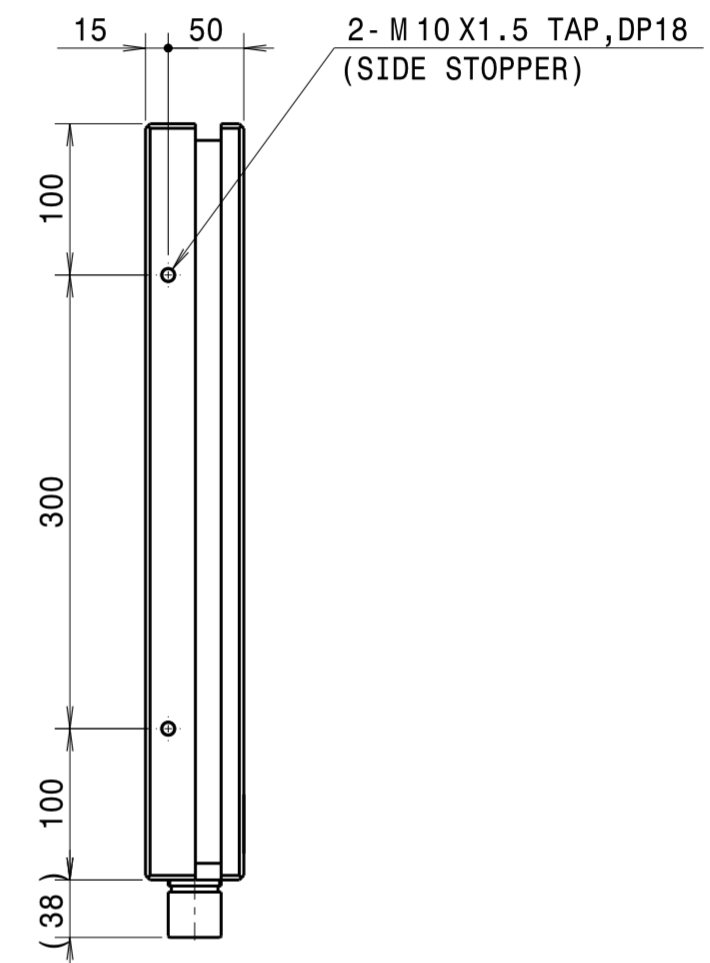
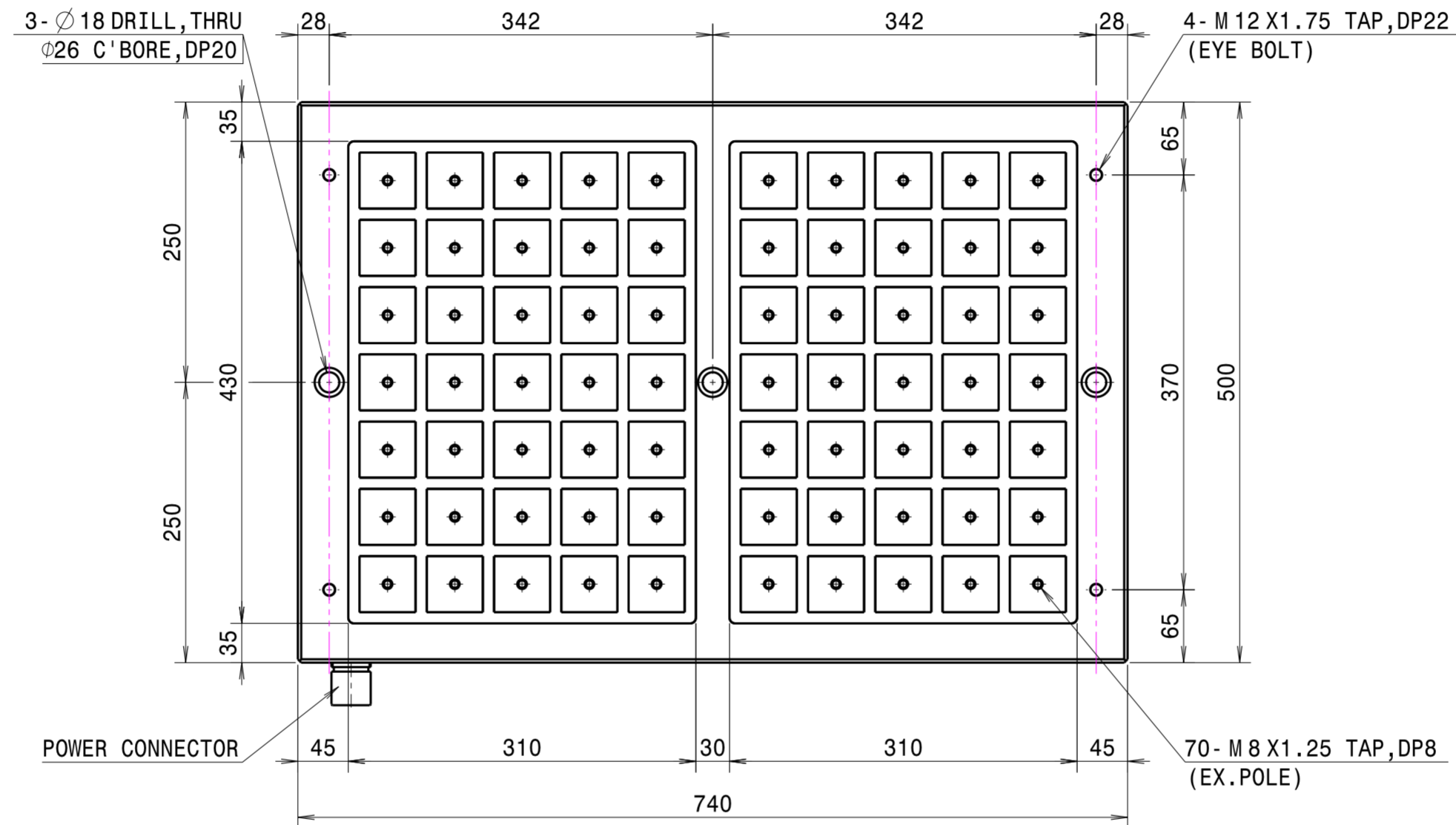
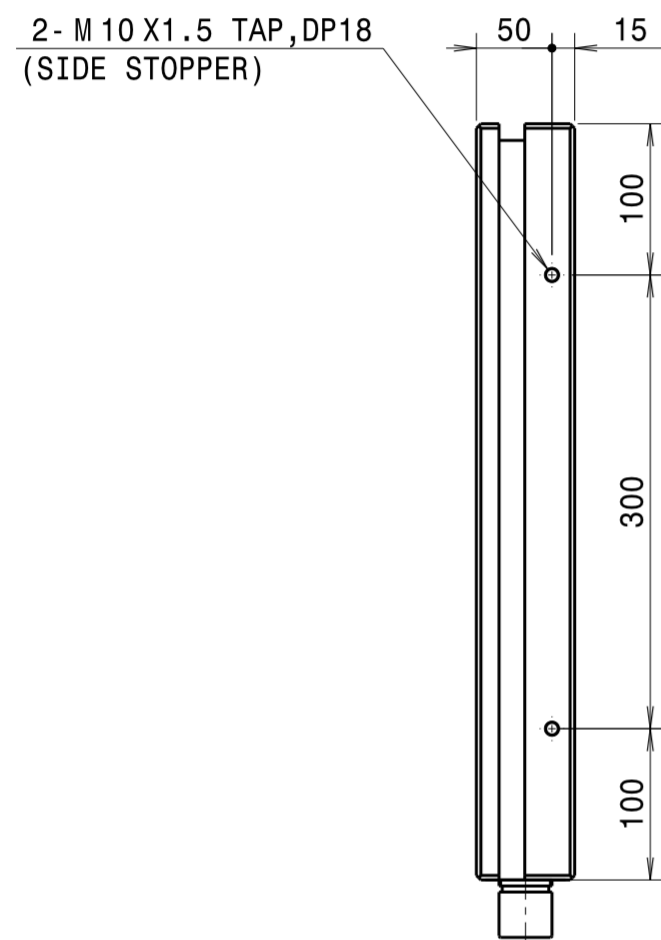
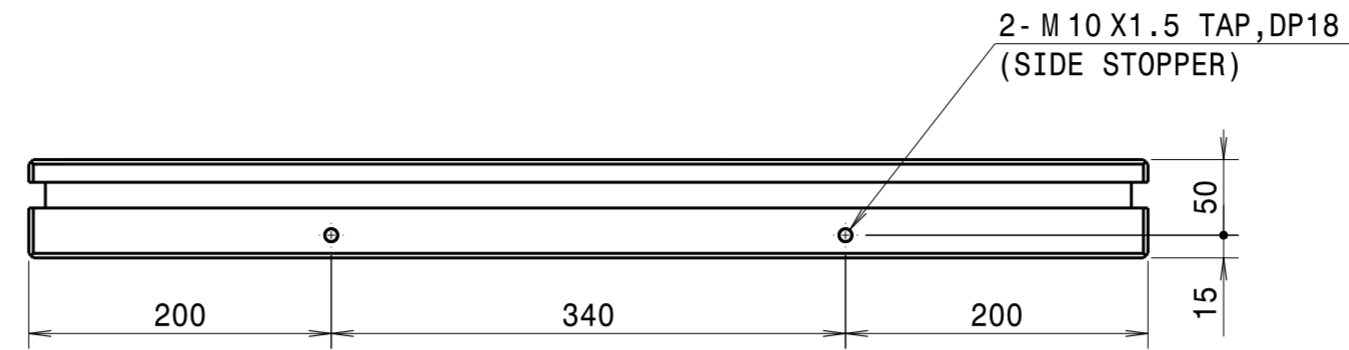
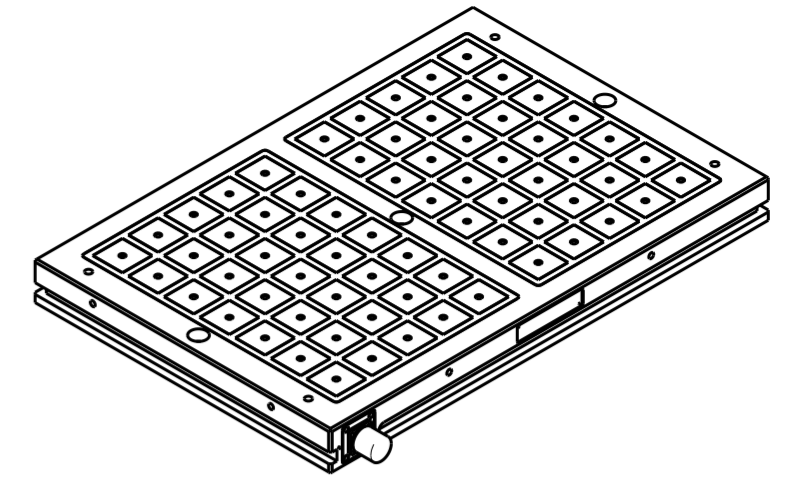
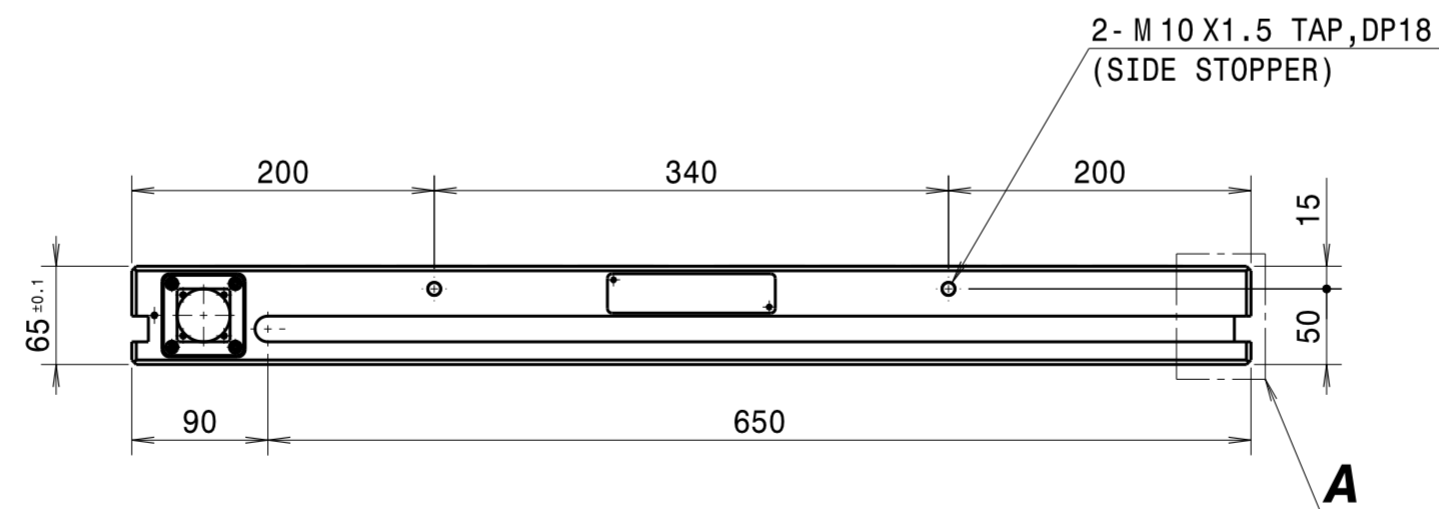

						SURFACE FINISH	~ (▽), (▽▽), (▽▽▽)	APPROVED		TITLE	SEP5050800 - HL_ASS'Y	Q'TY	1
						GENERAL TOLERNCE (MACHINING)		CHECKED		ASS'Y	N/A	W.T (kg)	N/A
						OVER	TO	GENERAL CHAMFER	C1.0	MODEL	N/A	SCALE	1/5
						- 6	±0.1	HEAT TREATMENT HARDNESS	H _R C N/A	CHECKED			
						6 - 30	±0.2	HEAT TREATMENT METHOD	N/A	DESIGNED	HS. CHO	DRG. NO.	A2
						30 - 120	±0.3	SURFACE TREATMENT	N/A	DRAWN	When	REF. DRG. NO.	SEP5050800 - HL
						120 - 315	±0.5						1/1
						315 - 1000	±0.8						
						1000 - 2000	±1.2						
						2000 - 4000	±2.0						
SUFFIX	MARK	SUBJECT			DATE	NAME	CHECKED						

