

SEP50503 (28POLE)

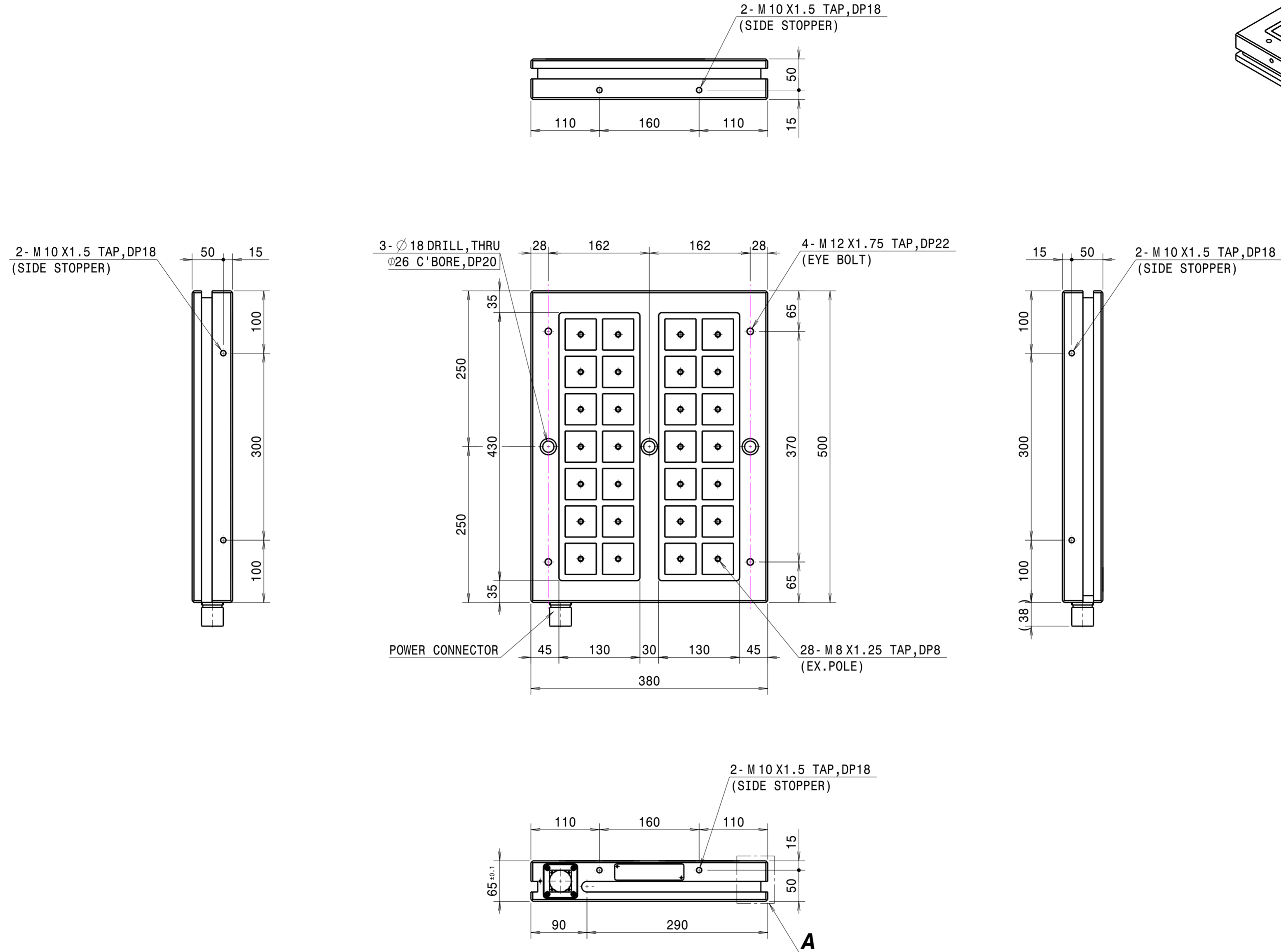
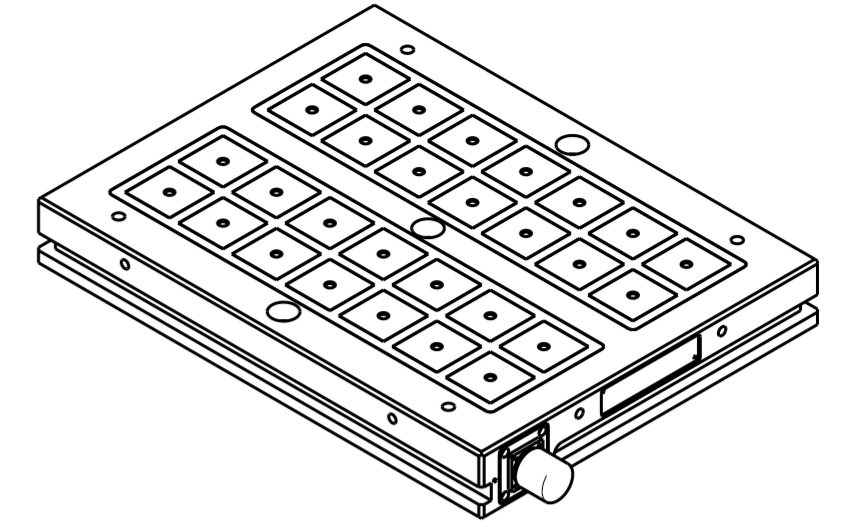

Detail A (2:3)
(SIDE SLOT)

						SURFACE FINISH	~ (▽), (▽▽), (▽▽▽)	APPROVED	TITLE		SEP5050300 - HL_ASS'Y	Q'TY	1		
						GENERAL TOLERANCE (MACHINING)	GENERAL CHAMFER	C1.0	CHECKED	ASS'Y		N/A		W.T (kg)	N/A
						OVER TO	HEAT TREATMENT HARDNESS	H _R C N/A	CHECKED	MODEL		N/A		SCALE	1/5
						- 6 ±0.1	HEAT TREATMENT METHOD	N/A	DESIGNED	REF. DRG. NO.		A2 SEP5050300 - HL		1/1	①
						6 - 30 ±0.2				DRAWN		When		N/A	
						30 - 120 ±0.3									
						120 - 315 ±0.5									
						315 - 1000 ±0.8									
						1000 - 2000 ±1.2									
						2000 - 4000 ±2.0									
SUFFIX	MARK	SUBJECT				DATE	NAME	CHECKED							