

SEP50406 (48POLE)

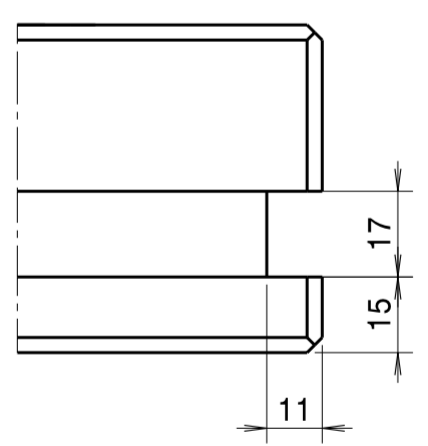

Detail A (2:3)
(SIDE SLOT)

						SURFACE FINISH	~ (▽), (▽▽), (▽▽▽)	APPROVED		TITLE	SEP5040600 - HL_ASS'Y	Q'TY	1
						GENERAL TOLERNCE (MACHINING)		CHECKED		ASS'Y	N/A	W.T (kg)	N/A
						OVER	TO			MODEL		SCALE	1/5
						- 6	±0.1			N/A			
						6 - 30	±0.2	GENERAL CHAMFER	C1.0	CHECKED			
						30 - 120	±0.3	HEAT TREATMENT HARDNESS	H _R C N/A	CHECKED			
						120 - 315	±0.5	HEAT TREATMENT METHOD	N/A	DESIGNED	HS.CHO		
						315 - 1000	±0.8	SURFACE TREATMENT	N/A	DRAWN	When		
						1000 - 2000	±1.2						
						2000 - 4000	±2.0						
SUFFIX	MARK	SUBJECT			DATE	NAME	CHECKED			REF. DRG. NO.	A2	SEP5040600 - HL	1/1

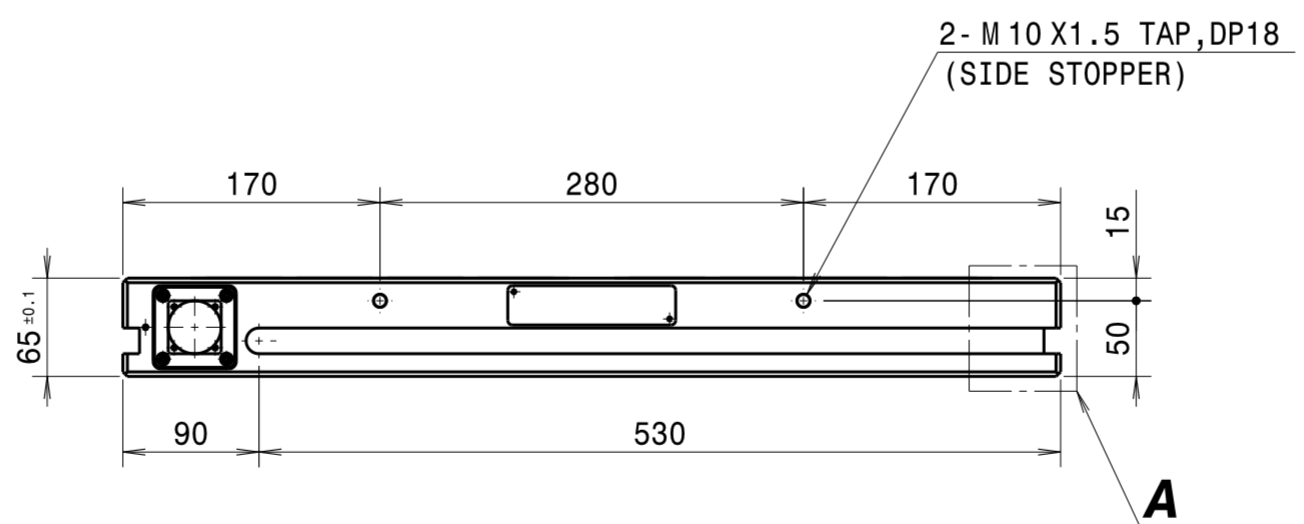
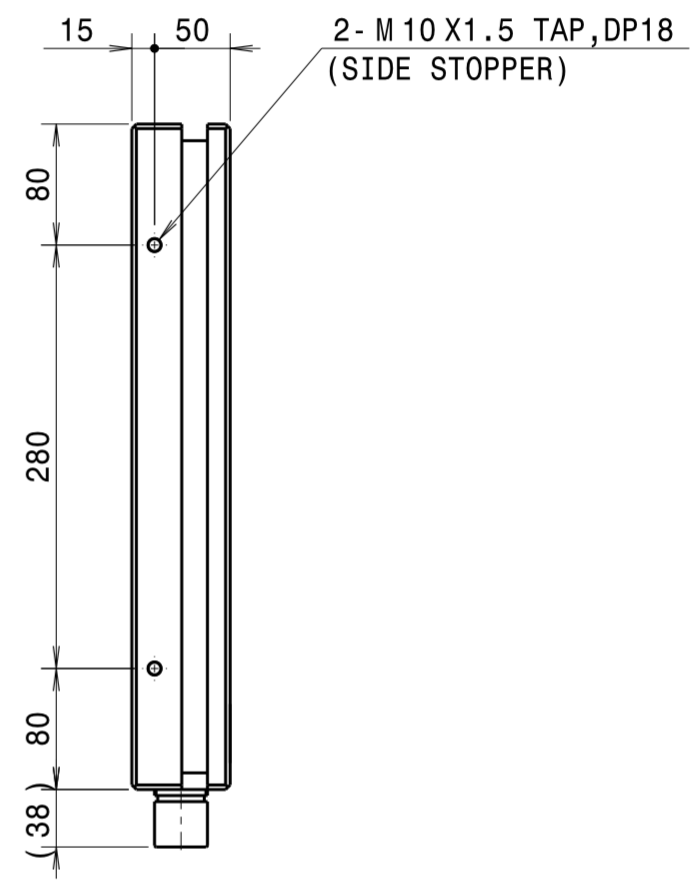
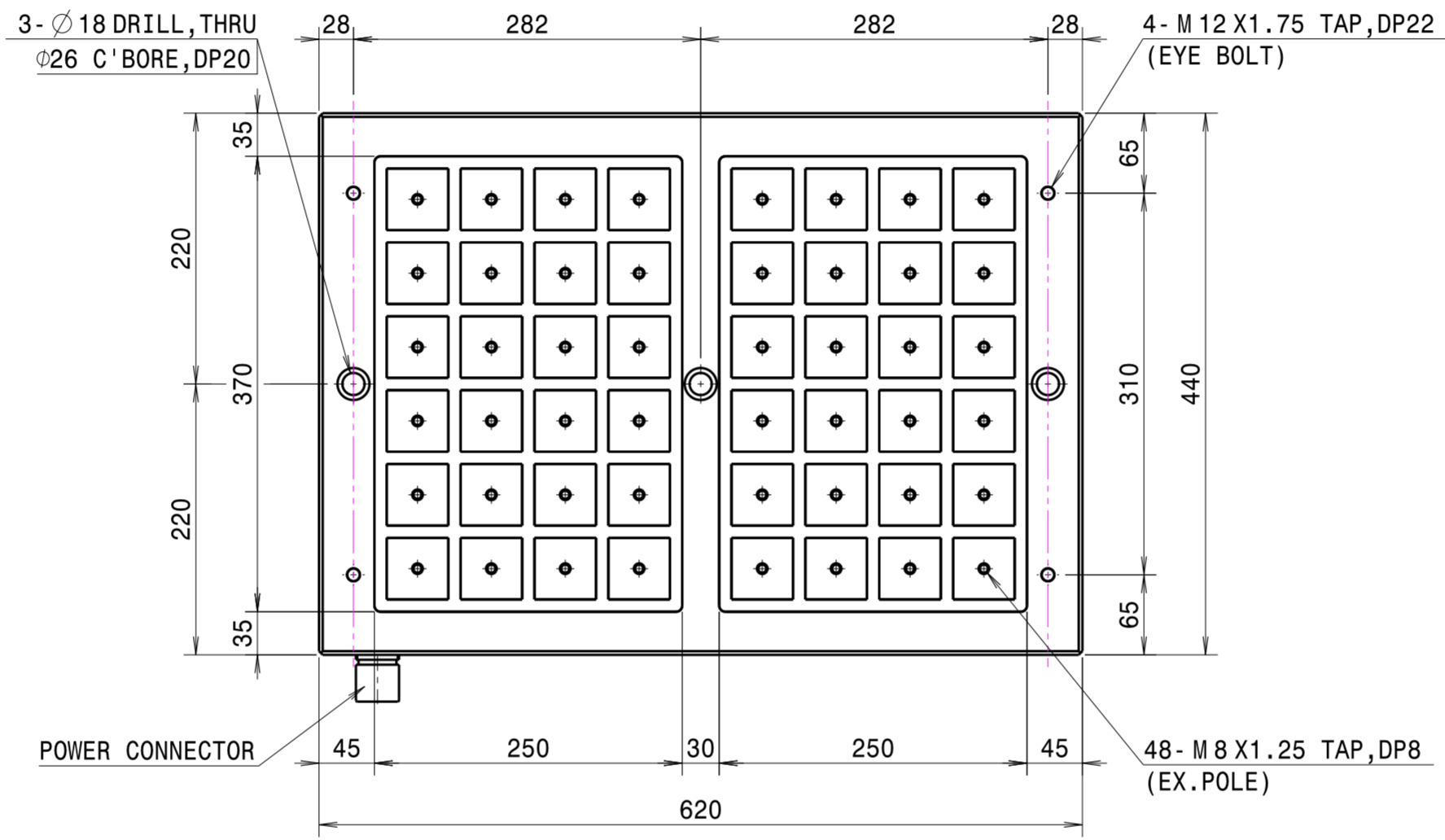
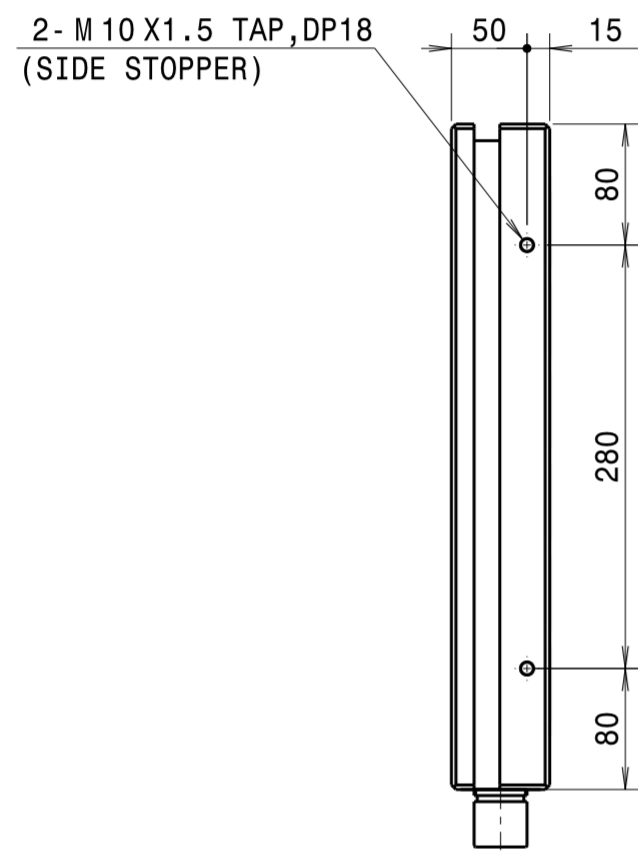
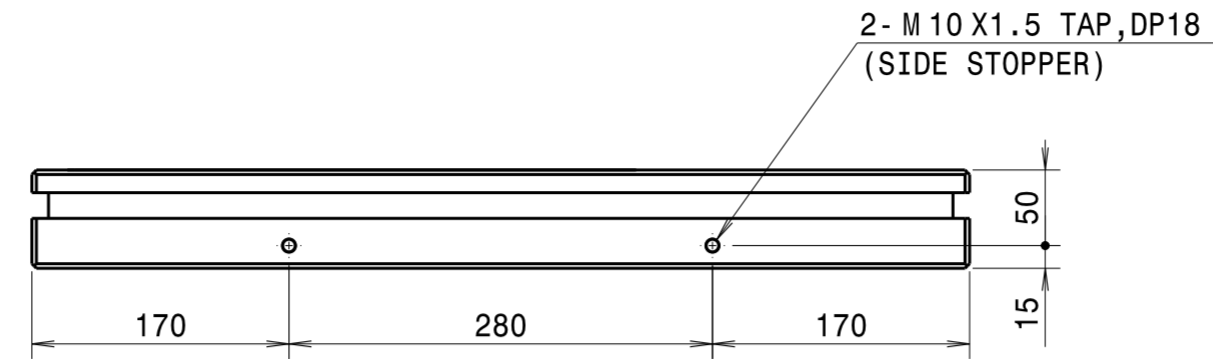
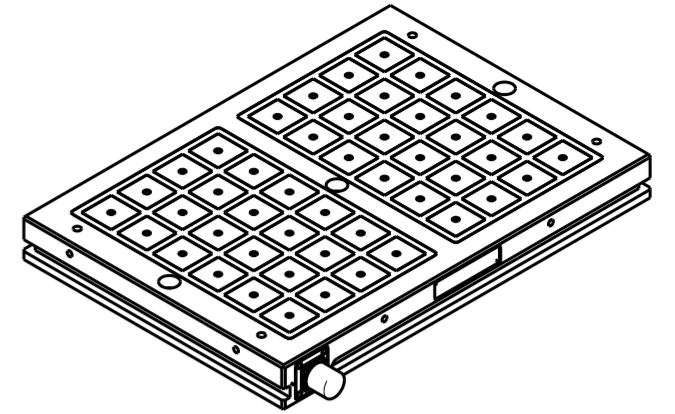