

SEP50405 (36POLE)

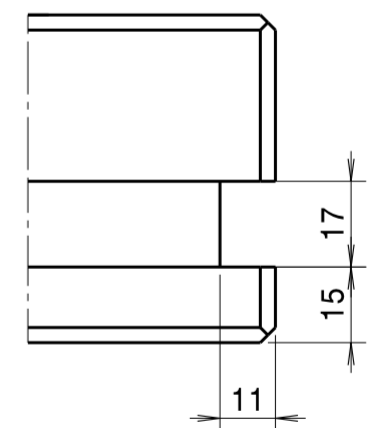

Detail A (2:3)
(SIDE SLOT)

								SURFACE FINISH	~ (▽), (▽▽), (▽▽▽)	APPROVED		TITLE	SEP5040500 - HL_ASS'Y	Q'TY	1
								GENERAL TOLERANCE (MACHINING)		CHECKED		ASS'Y	N/A	W.T (kg)	N/A
								OVER	TO	GENERAL CHAMFER		MODEL		SCALE	1/5
								- 6	±0.1	H _r C	N/A				
								6 - 30	±0.2	HEAT TREATMENT					
								30 - 120	±0.3	HARDNESS					
								120 - 315	±0.5	HEAT TREATMENT METHOD					
								315 - 1000	±0.8			DESIGNED	HS.CHO	REF. DRG. NO.	A2
								1000 - 2000	±1.2						SEP5040500 - HL
								2000 - 4000	±2.0	SURFACE TREATMENT					1/1
SUFFIX	MARK		SUBJECT		DATE	NAME	CHECKED				DRAWN	When			

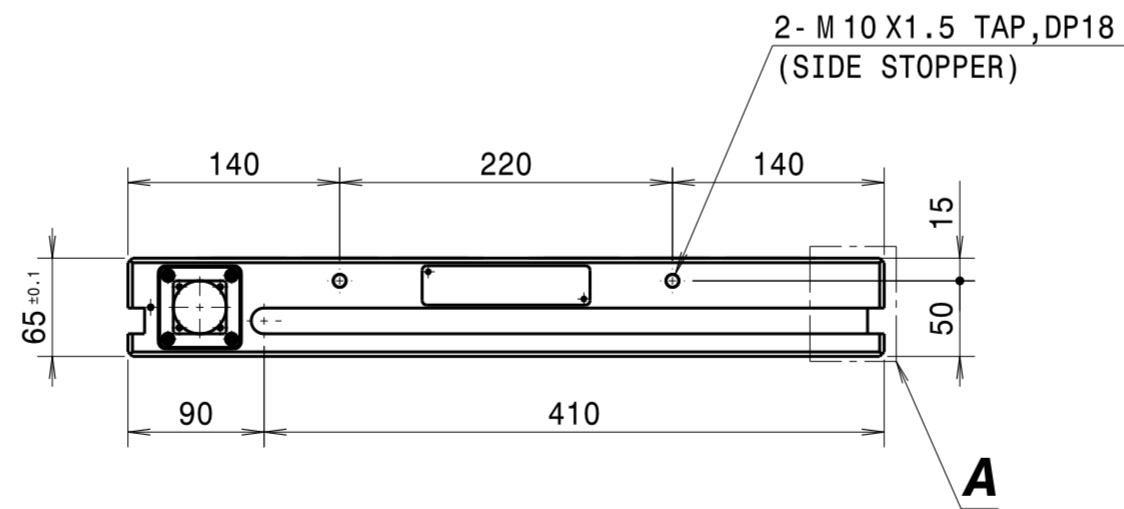
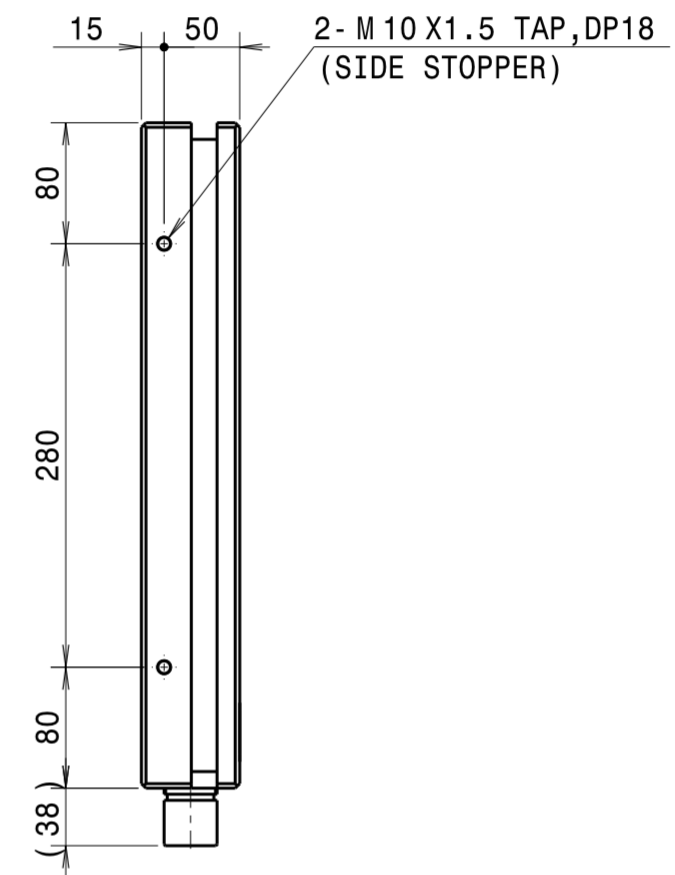
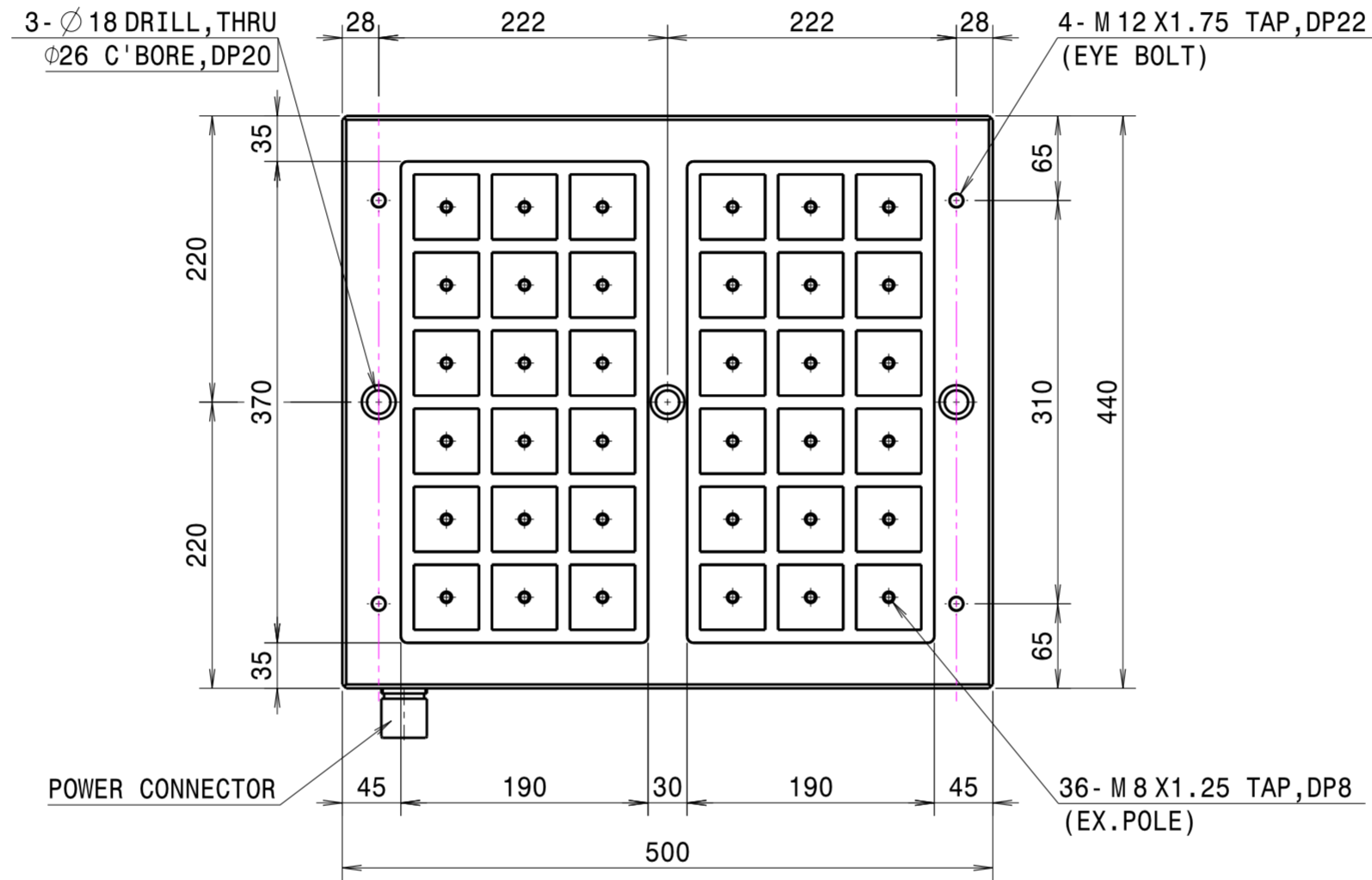
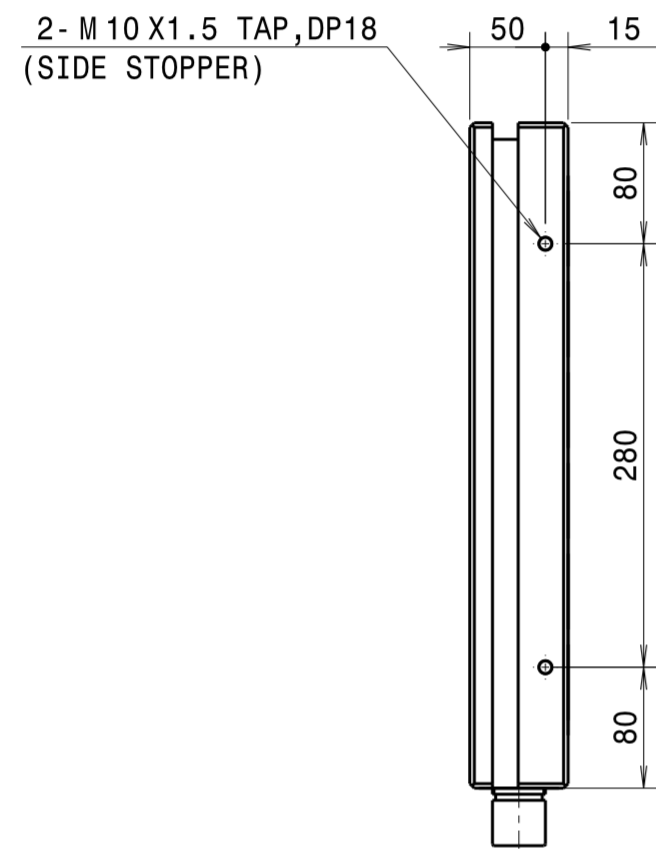
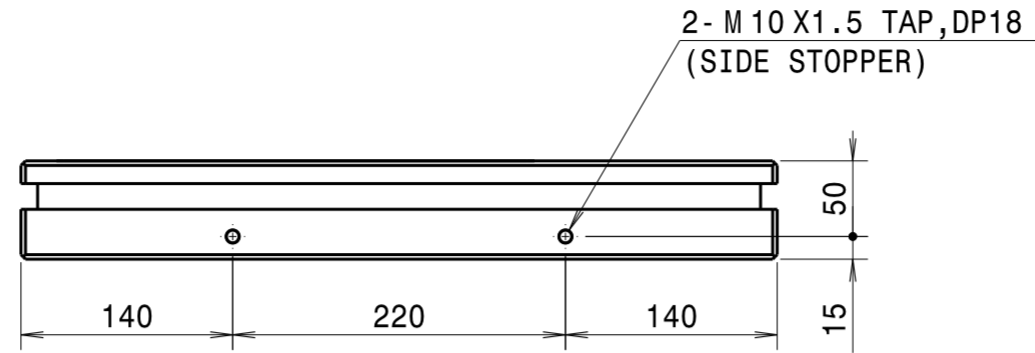
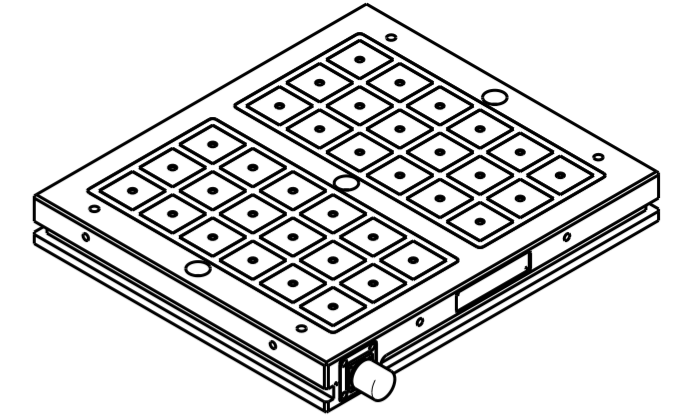