

SEP50403 (24POLE)

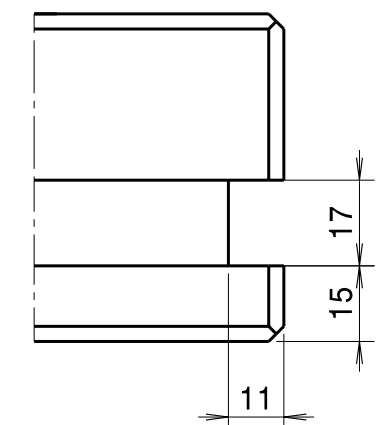
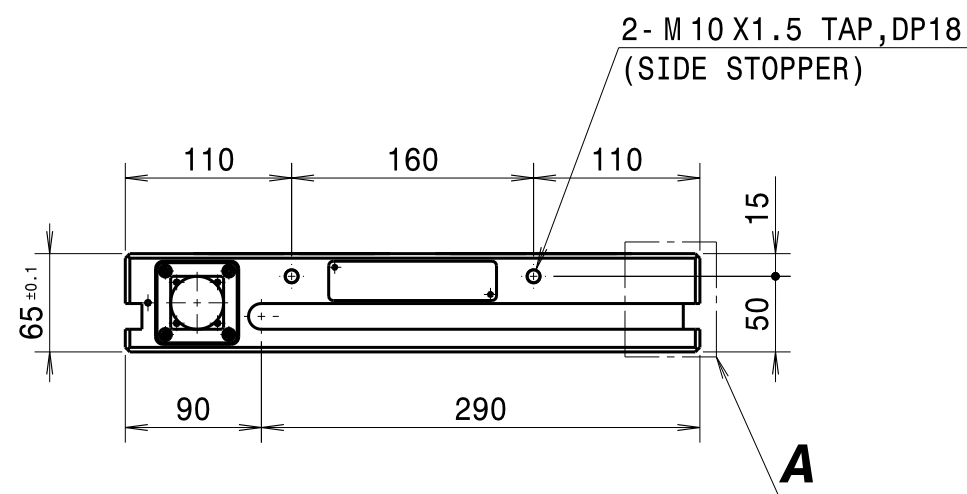
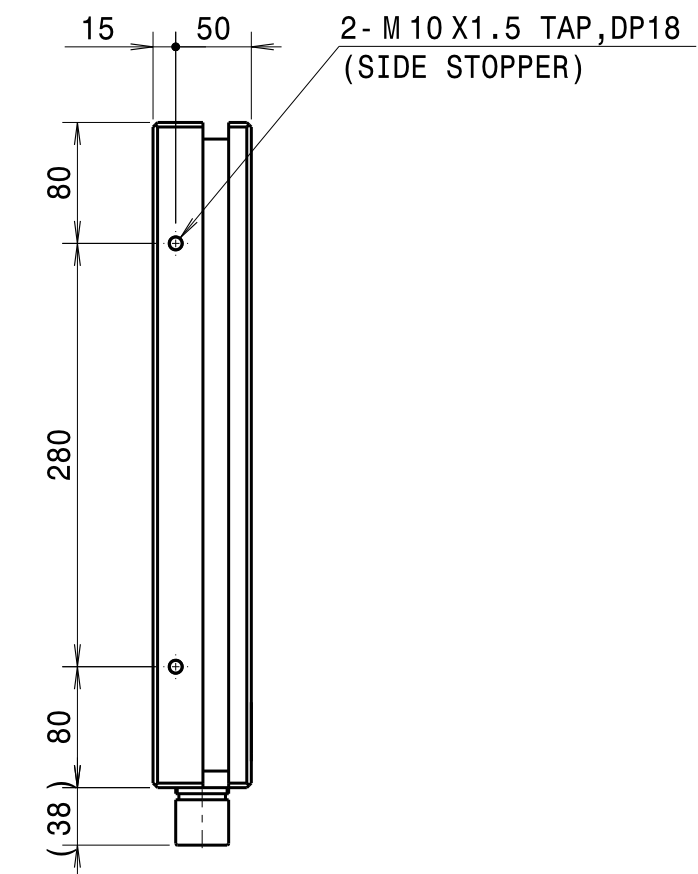
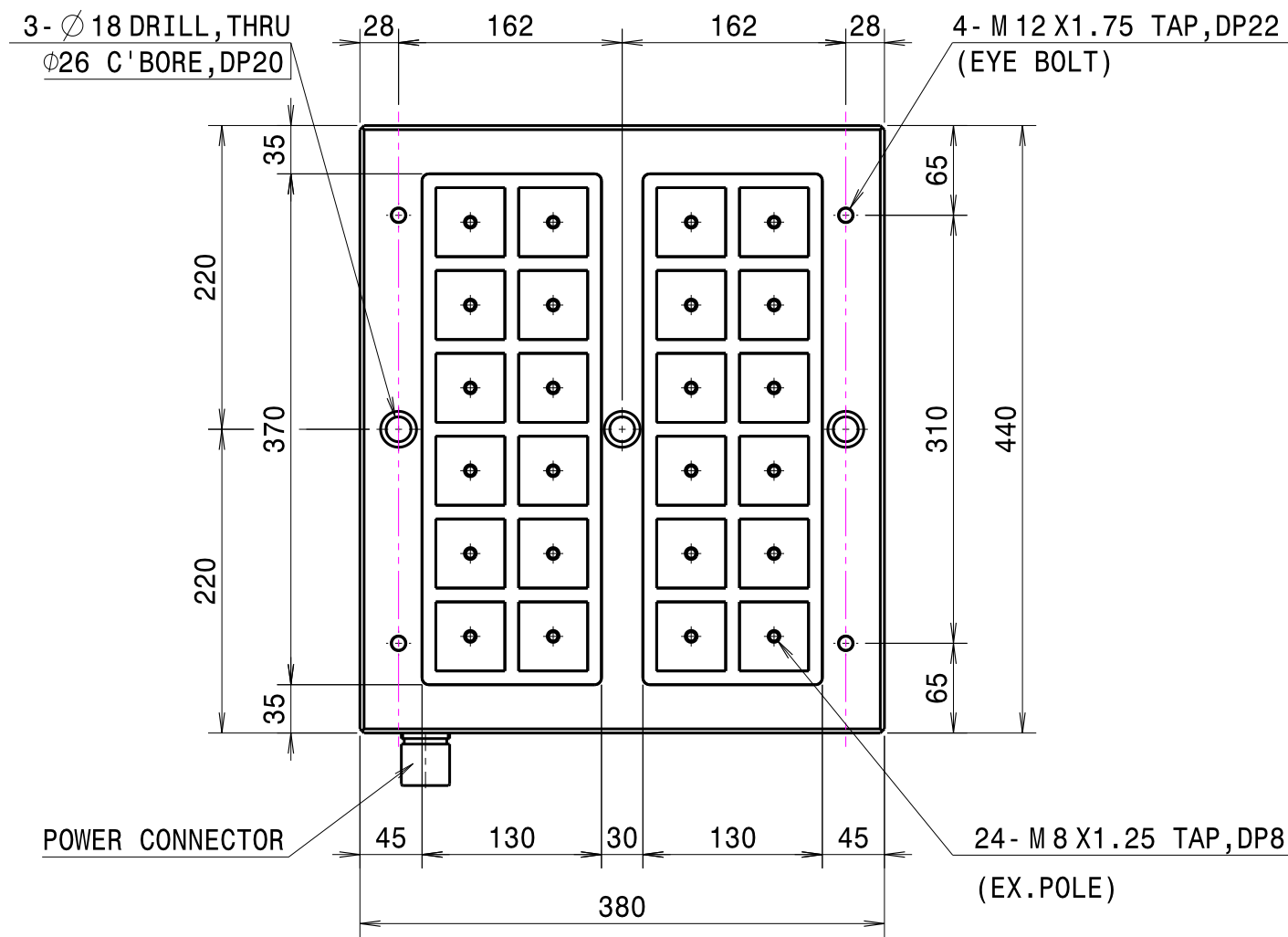
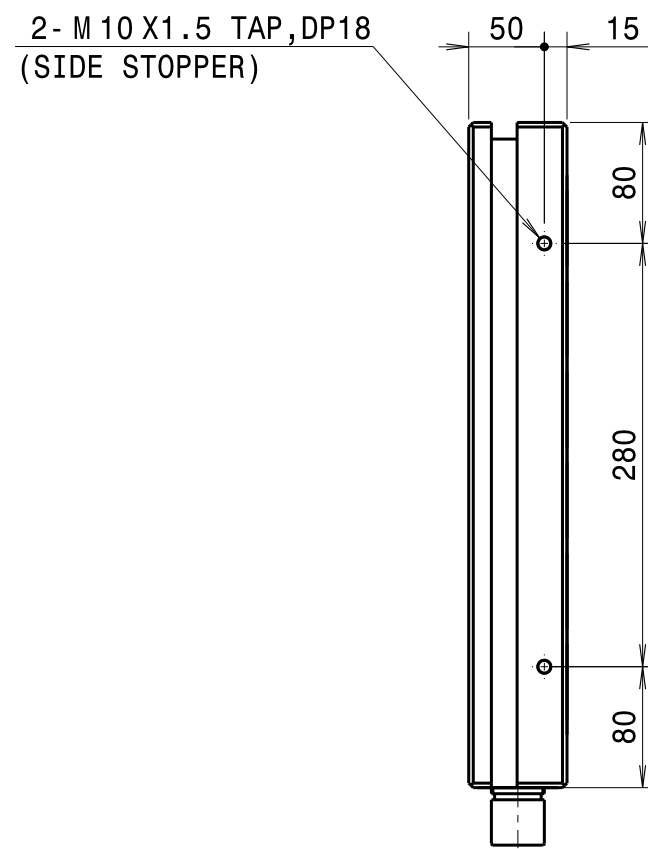
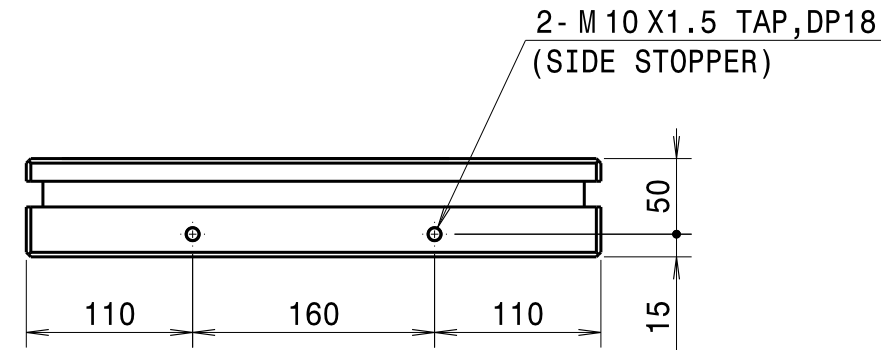
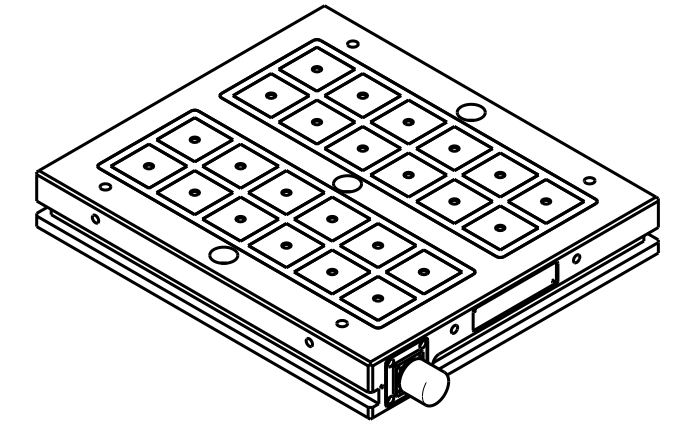

Detail A (2:3)
(SIDE SLOT)

						SURFACE FINISH	$\sim (\nabla), (\nabla\nabla), (\nabla\nabla\nabla)$	APPROVED		TITLE	SEP5040300-HL_AS'Y	Q'TY	1	
						GENERAL TOLERNCE (MACHINING)	GENERAL CHAMFER	C1.0	CHECKED		ASS'Y	N/A	W.T (kg)	N/A
						OVER TO	HEAT TREATMENT HARDNESS	H _R C N/A	CHECKED		MODEL	N/A	SCALE	1/5
						6 - 30 ±0.2	HEAT TREATMENT METHOD	N/A	DESIGNED	HS.CHO	DRG. NO.	A2	REF. DRG. NO.	SEP5040300-HL 1/1
						90 - 120 ±0.3	SURFACE TREATMENT	N/A	DRAWN	When				
						120 - 315 ±0.5								
						315 - 1000 ±0.8								
						1000 - 2000 ±1.2								
						2000 - 4000 ±2.0								
SUFFIX	MARK	SUBJECT			DATE	NAME	CHECKED							