

SEP50306 (32POLE)

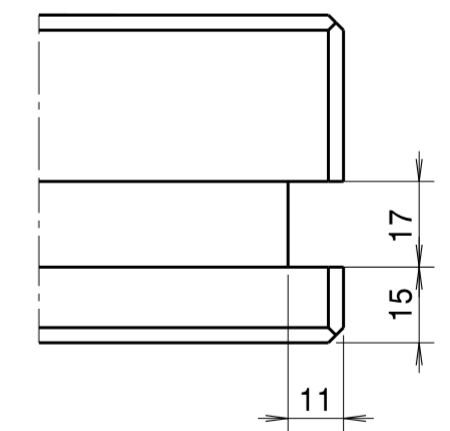

Detail A (2:3)
(SIDE SLOT)

						SURFACE FINISH	$\sim (\nabla), (\nabla\nabla), (\nabla\nabla\nabla)$	APPROVED		TITLE	SEP5030600 - HL_ASS'Y	Q'TY	1
						GENERAL TOLERANCE (MACHINING)		CHECKED		ASS'Y	N/A	W.T (kg)	N/A
						OVER	TO			MODEL		SCALE	1/5
						- 6	±0.1			N/A			
						6 - 30	±0.2			MAT.	N/A		
						30 - 120	±0.3			DRG. NO.	A2		
						120 - 315	±0.5		DESIGNED	HS. CHO	REF. DRG. NO.	SEP5030600 - HL	1/1
						315 - 1000	±0.8						
						1000 - 2000	±1.2						
						2000 - 4000	±2.0		DRAWN	When			
SUFFIX	MARK	SUBJECT			DATE	NAME	CHECKED						

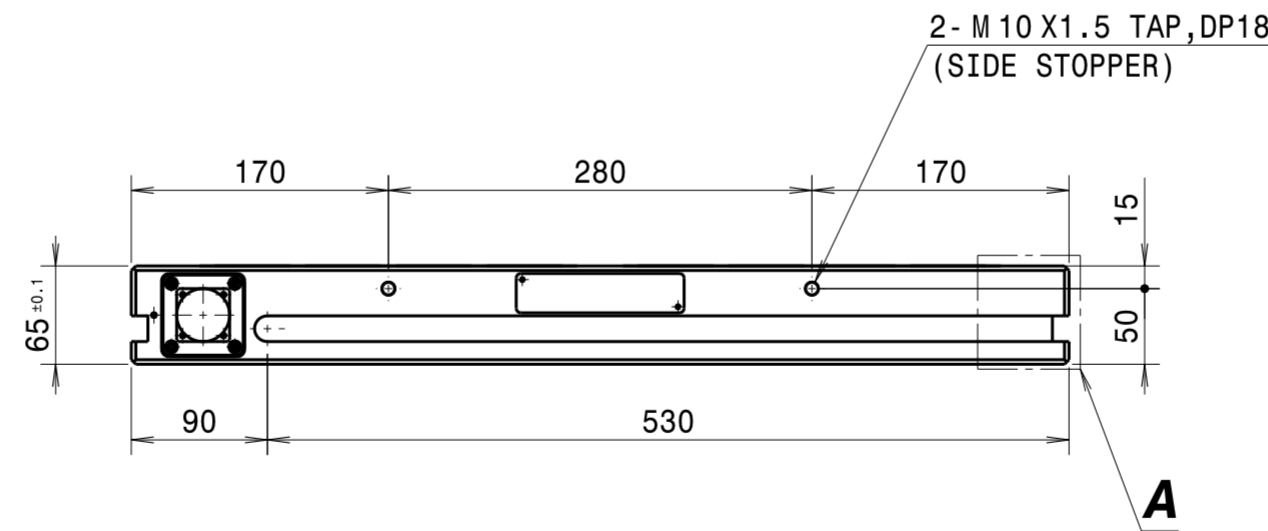
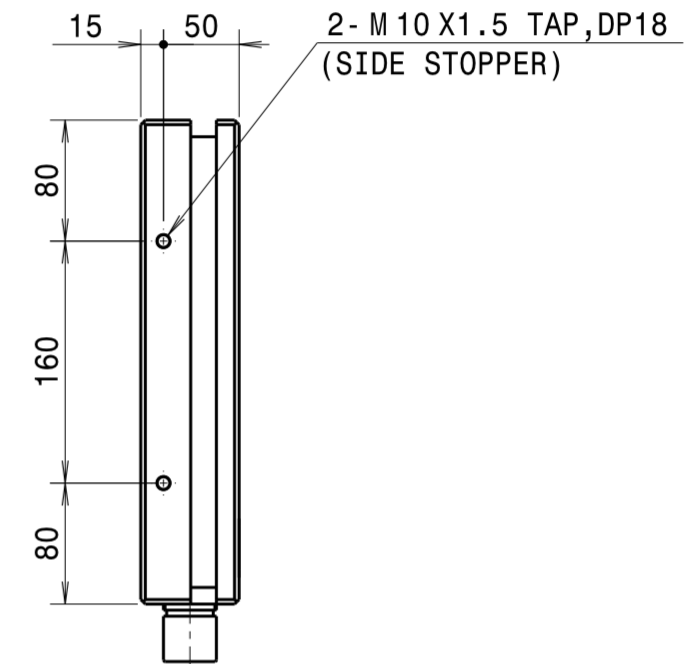
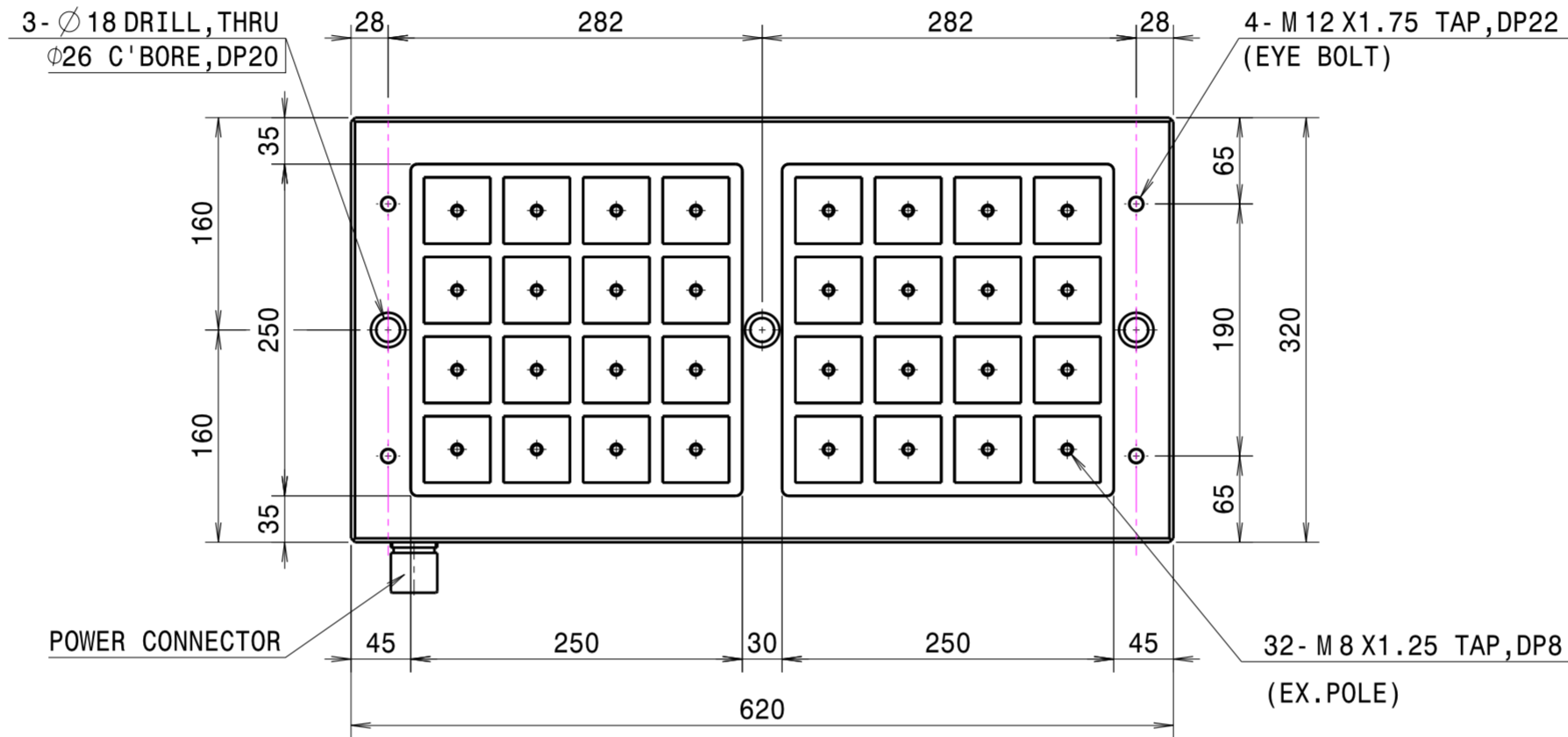
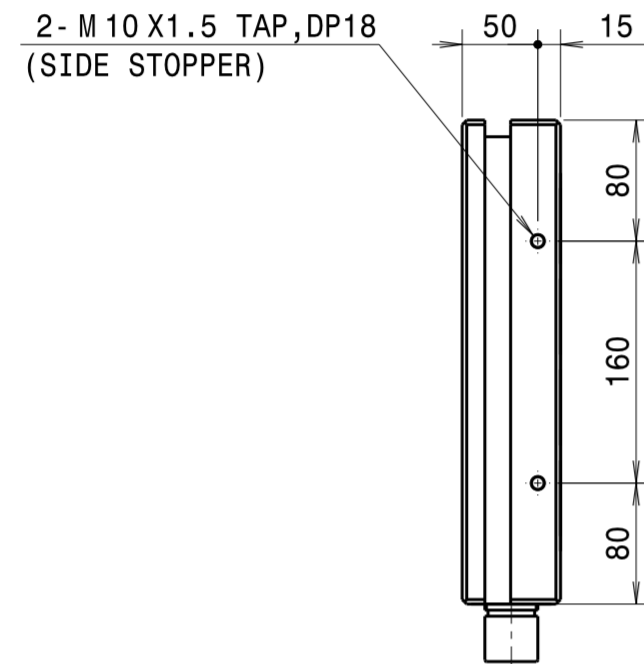
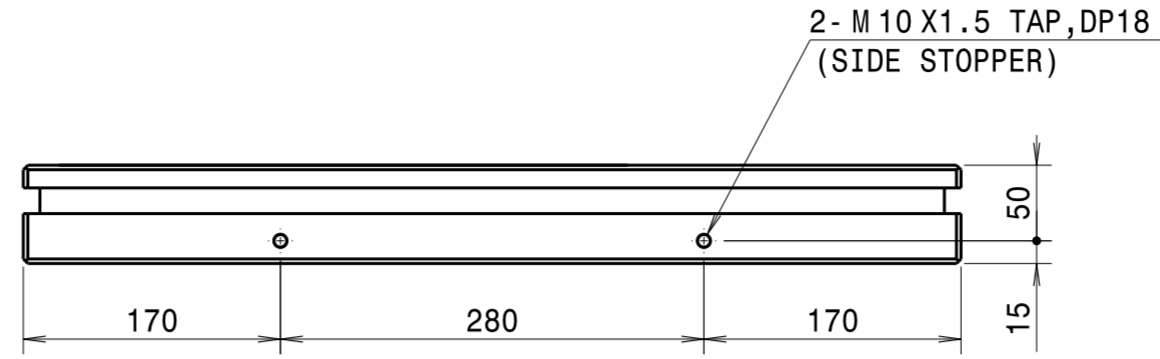
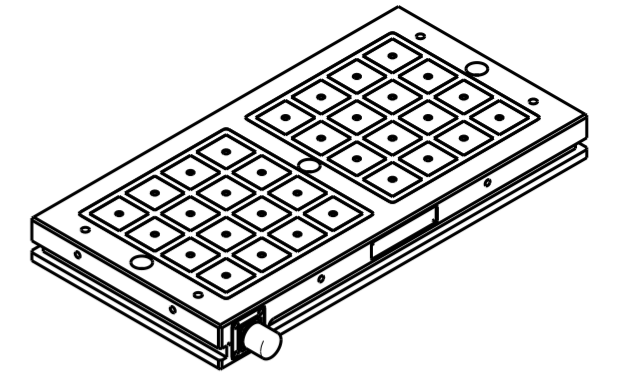