

# SEP50305 (24POLE)

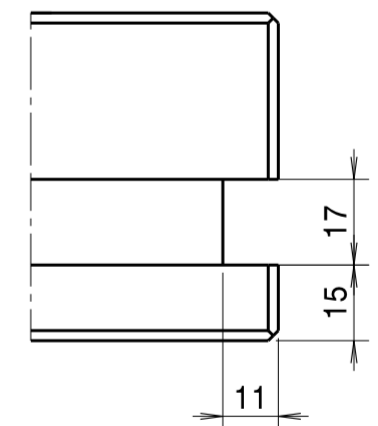

**Detail A (2:3)**  
**(SIDE SLOT)**

						SURFACE FINISH	~ (▽), (▽▽), (▽▽▽)	APPROVED		TITLE	SEP5030500 - HL_ASS'Y	Q'TY	1
						GENERAL TOLERANCE (MACHINING)		CHECKED		ASS'Y	N/A	W.T (kg)	N/A
						OVER	TO	GENERAL CHAMFER	C1.0	MODEL		SCALE	1/4
						- 6	±0.1	HEAT TREATMENT HARDNESS	H <sub>RC</sub> N/A	MAT.	N/A		
						6 - 30	±0.2	HEAT TREATMENT METHOD	N/A	DRG. NO.	A3	REF. DRG. NO.	SEP5030500 - HL
						30 - 120	±0.3		DESIGNED	HS.CHO			1/1
						120 - 315	±0.5						
						315 - 1000	±0.8						
						1000 - 2000	±1.2	SURFACE TREATMENT	N/A	DRAWN	When		
						2000 - 4000	±2.0						
SUFFIX	MARK	SUBJECT			DATE	NAME	CHECKED						

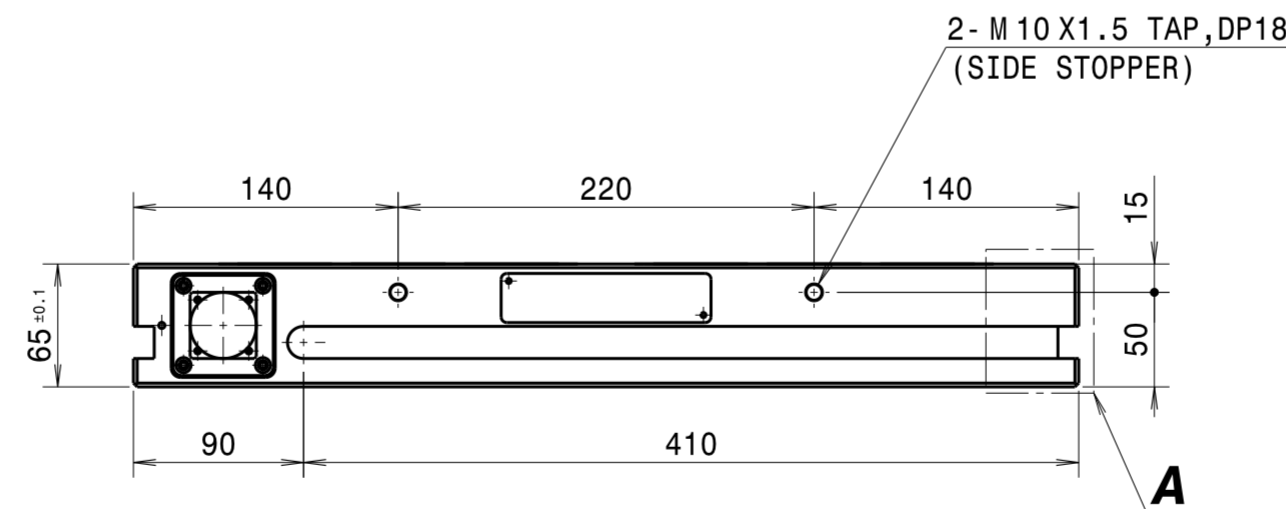
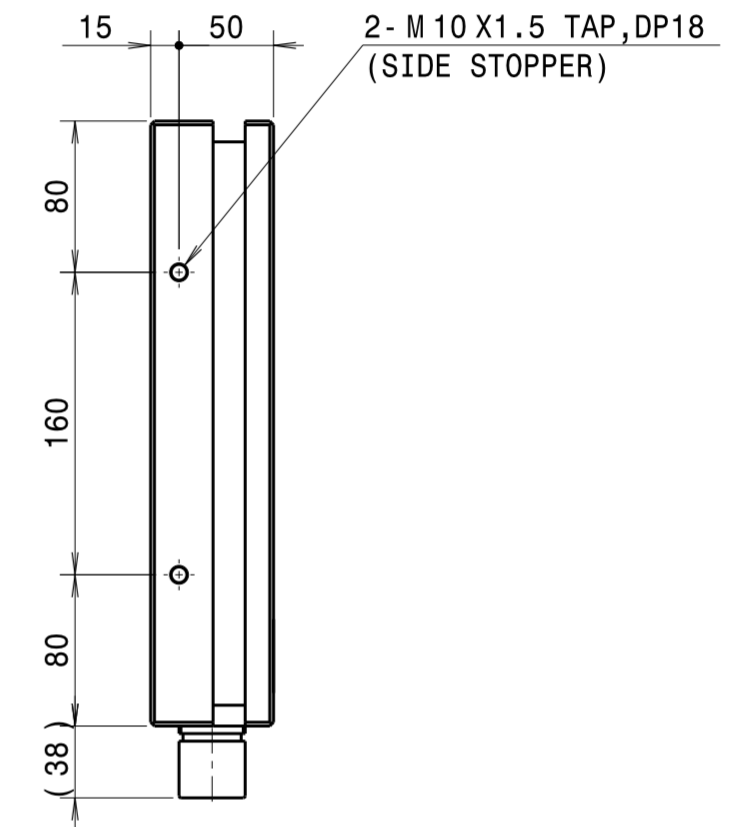
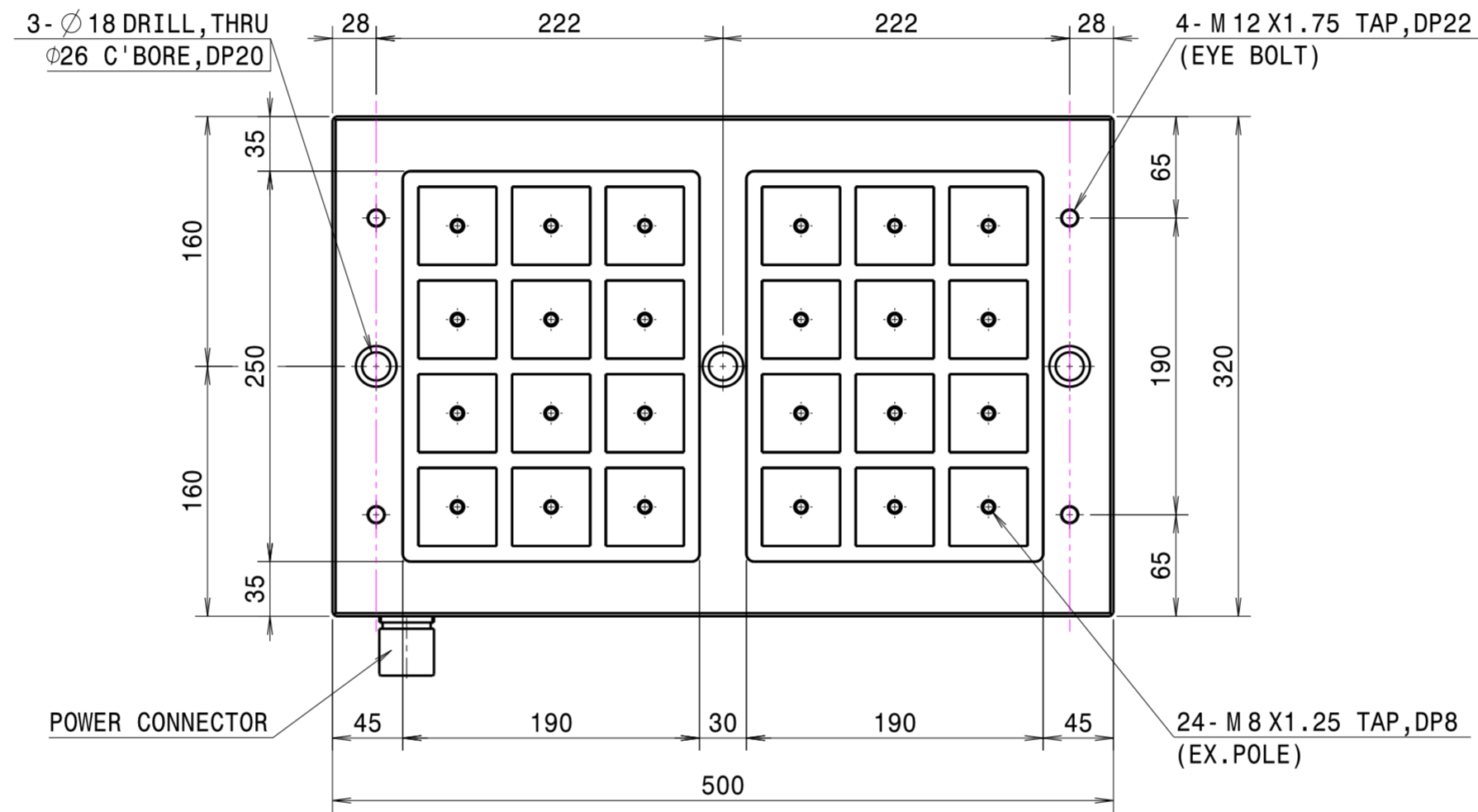
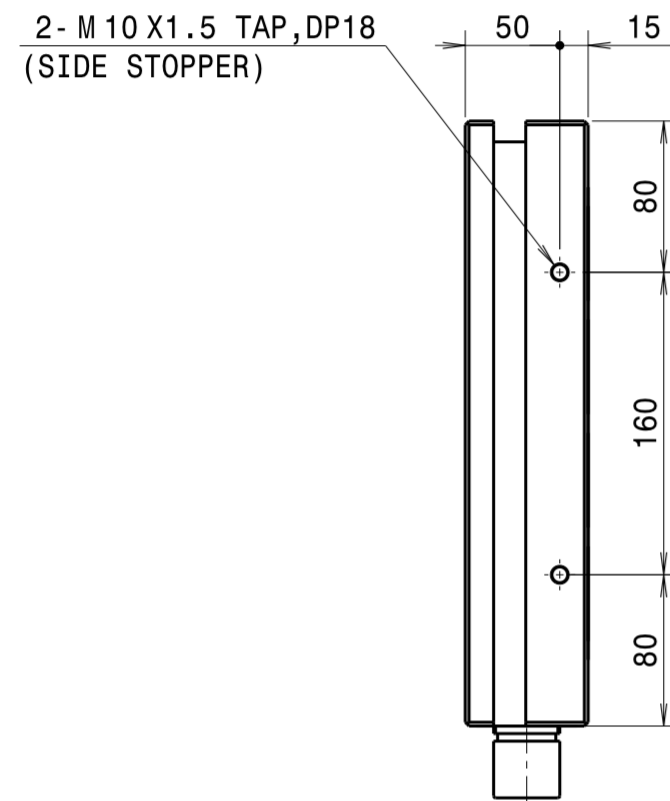
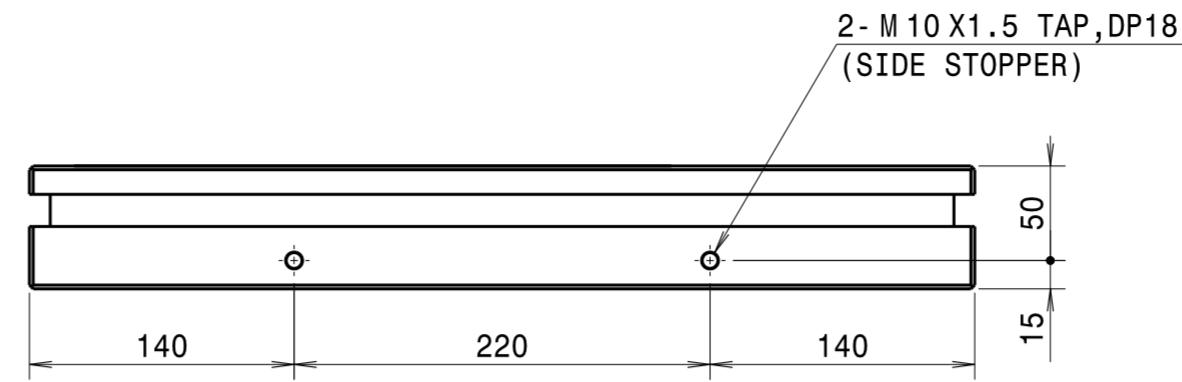
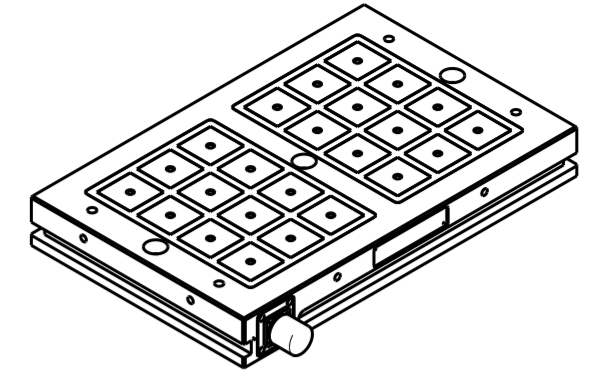