

SEP50303 (16POLE)

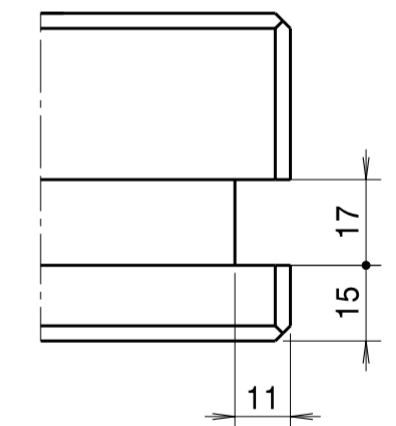
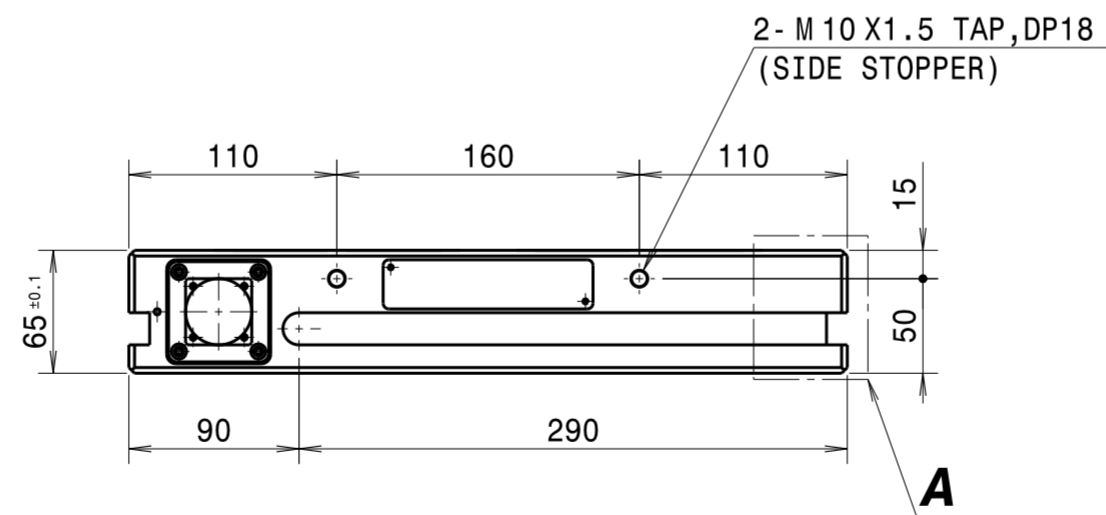
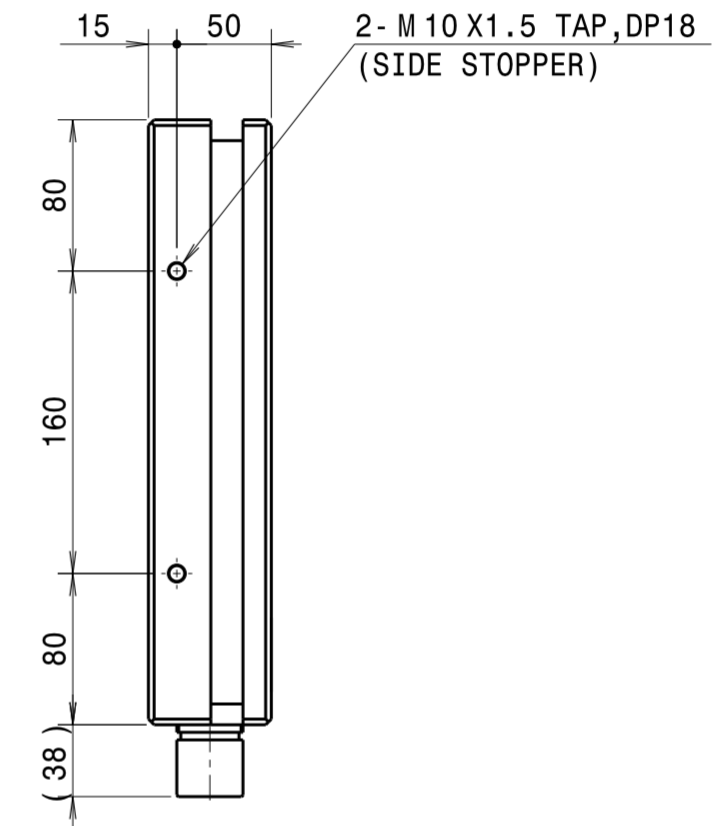
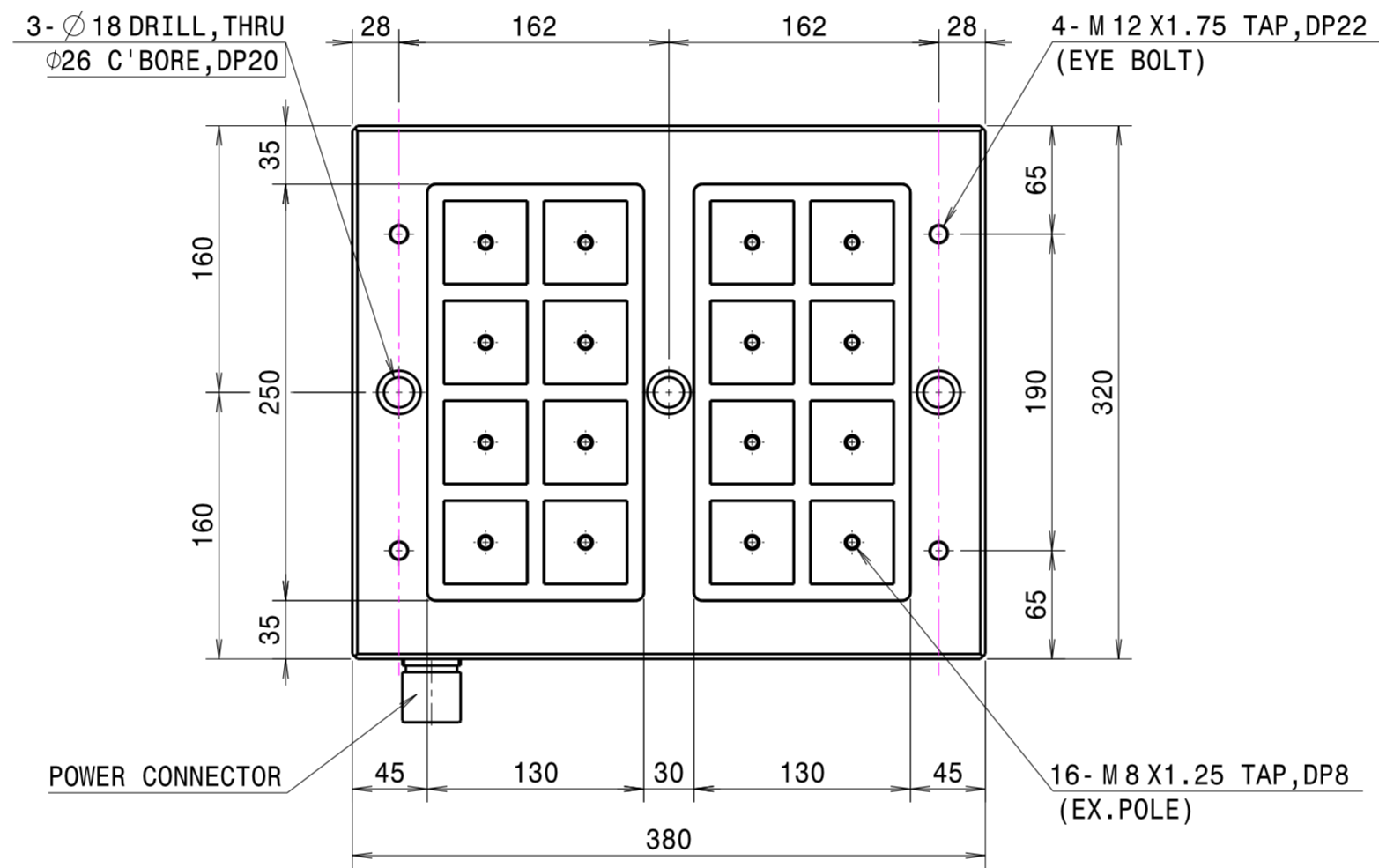
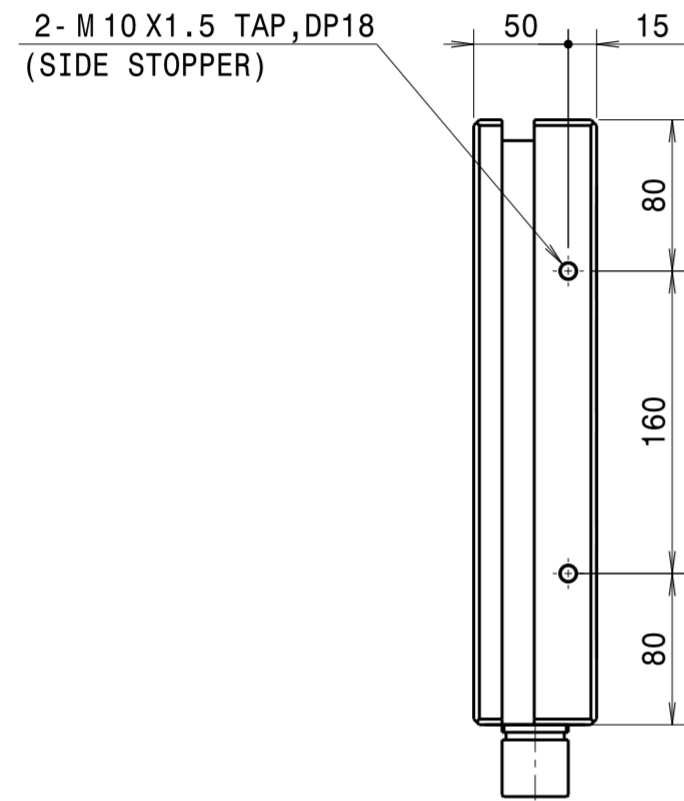
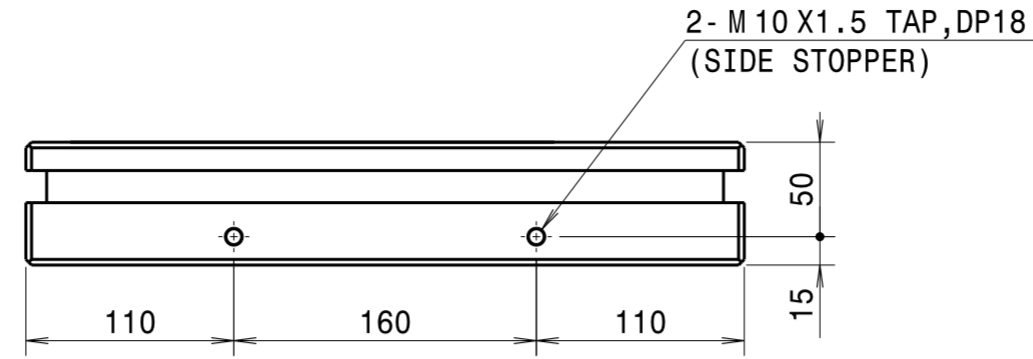
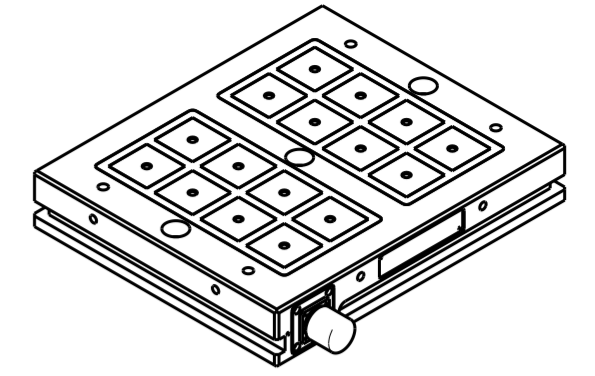

**Detail A (2:3)
(SIDE SLOT)**

| | | | | | | | | | | | | | | | | | | |
|--------|------|---------|--|--|--|------------------------------|--------------------|-------------------------|------------------|----------|---------|-------|-----------------------|-------------|-----------------|----------|-------|-----|
| | | | | | | SURFACE FINISH | ~ (▽), (▽▽), (▽▽▽) | | APPROVED | | | TITLE | SEP5030300 - HL_ASS'Y | | Q'TY | 1 | | |
| | | | | | | GENERAL TOLERNCE (MACHINING) | GENERAL CHAMFER | C1.0 | | CHECKED | | | ASS'Y | N/A | | W.T (kg) | N/A | |
| | | | | | | OVER | TO | HEAT TREATMENT HARDNESS | H _R C | N/A | CHECKED | | | MODEL | N/A | | SCALE | 1/4 |
| | | | | | | - 6 | ±0.1 | HEAT TREATMENT METHOD | N/A | DESIGNED | HS.CHO | | REF. DRG. NO. | DRG. NO. A3 | SEP5030300 - HL | | 1/1 | ④ |
| | | | | | | 6 - 30 | ±0.2 | SURFACE TREATMENT | N/A | DRAWN | When | | N/A | | 상원이엔지 | | | |
| | | | | | | 30 - 120 | ±0.3 | | | | | | | | | | | |
| | | | | | | 120 - 315 | ±0.5 | | | | | | | | | | | |
| | | | | | | 315 - 1000 | ±0.8 | | | | | | | | | | | |
| | | | | | | 1000 - 2000 | ±1.2 | | | | | | | | | | | |
| | | | | | | 2000 - 4000 | ±2.0 | | | | | | | | | | | |
| SUFFIX | MARK | SUBJECT | | | | DATE | NAME | CHECKED | | | | | | | | | | |