

SEP50206 (24POLE)

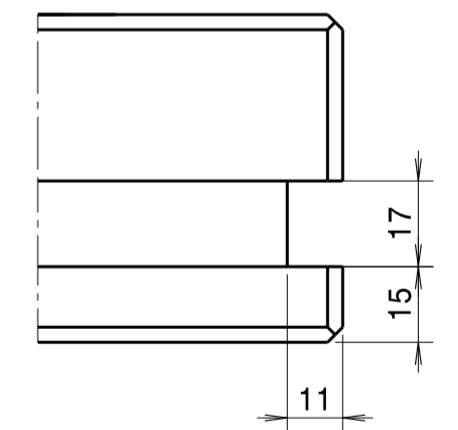
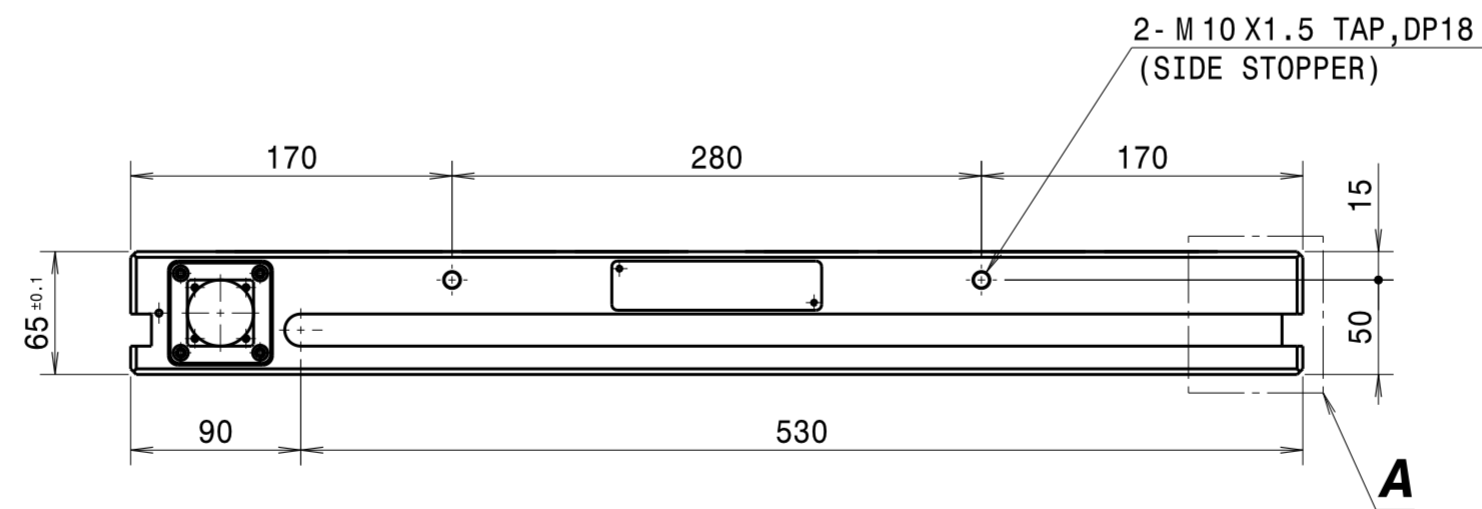
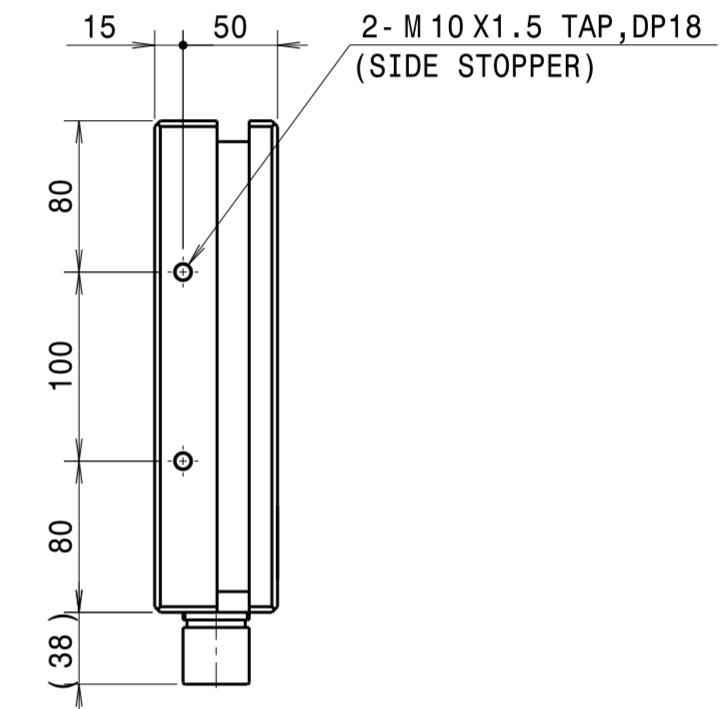
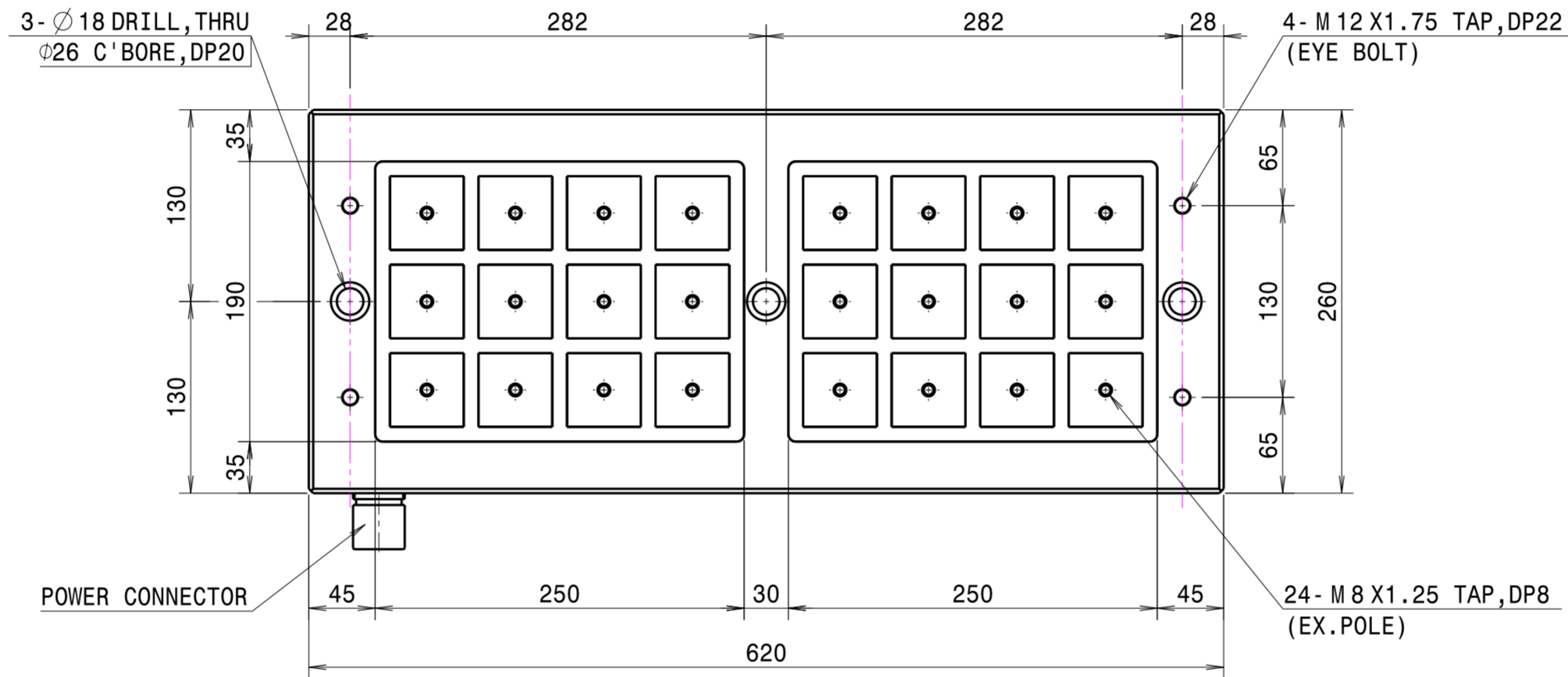
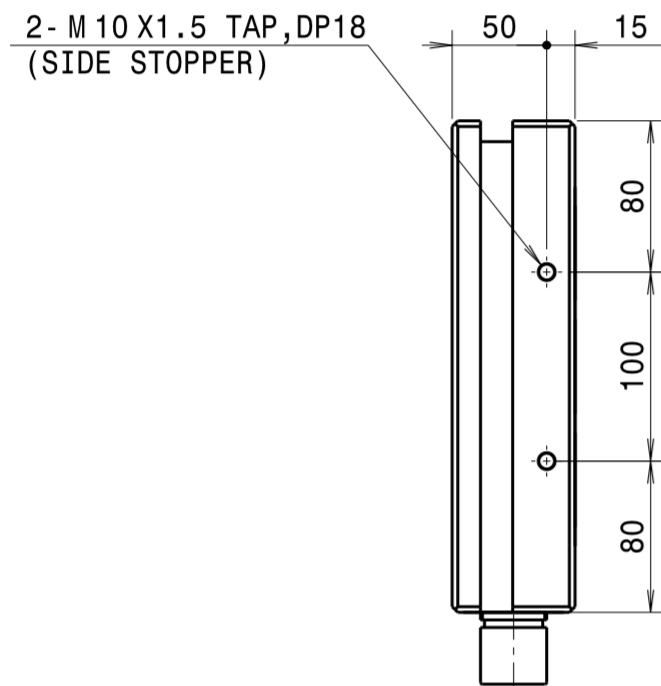
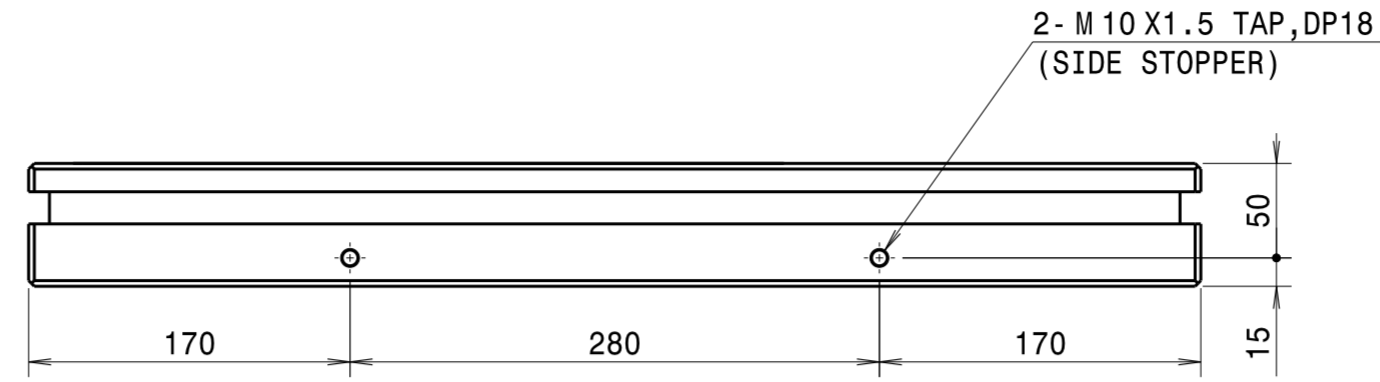
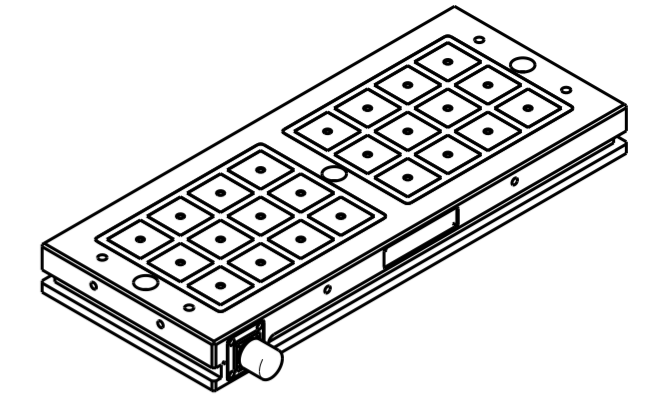

Detail A (2:3)
(SIDE SLOT)

						SURFACE FINISH	$\sim (\nabla), (\nabla\nabla), (\nabla\nabla\nabla)$	APPROVED	TITLE	SEP5020600 - HL_ASS'Y	Q'TY	1	
						GENERAL TOLERANCE (MACHINING)	GENERAL CHAMFER	C1.0	CHECKED	ASS'Y	N/A	W.T (kg)	N/A
						OVER	TO	HEAT TREATMENT HARDNESS	H _R C	N/A	CHECKED	MODEL	N/A
						- 6	±0.1	HEAT TREATMENT METHOD	N/A	DESIGNED	HS.CHO	MAT.	N/A
						6 - 30	±0.2	SURFACE TREATMENT	N/A	DRAWN	When	REF. DRG. NO.	A3
						30 - 120	±0.3					DRG. NO.	SEP5020600 - HL
						120 - 315	±0.5					SCALE	1/1
						315 - 1000	±0.8						1/1
						1000 - 2000	±1.2						
						2000 - 4000	±2.0						
SUFFIX	MARK	SUBJECT		DATE	NAME	CHECKED							